

3G STORM SERIES[®]
WHEELCHAIRS

ARROW[®] RWD
TORQUE[™] SP RWD
RANGER X[™] RWD

DEALER: THIS MANUAL MUST BE GIVEN TO THE USER
OF THE WHEELCHAIR.

USER: BEFORE USING THIS WHEELCHAIR, READ THIS
MANUAL AND SAVE FOR FUTURE REFERENCE.



WARNING

WARNING

DO NOT OPERATE THIS EQUIPMENT WITHOUT FIRST READING AND UNDERSTANDING THIS MANUAL. IF YOU ARE UNABLE TO UNDERSTAND THE WARNINGS, CAUTIONS, AND INSTRUCTIONS, CONTACT A HEALTHCARE PROFESSIONAL, DEALER OR TECHNICAL PERSONNEL IF APPLICABLE BEFORE ATTEMPTING TO USE THIS EQUIPMENT - OTHERWISE INJURY OR DAMAGE MAY RESULT.

SECTIONS OTHER THAN THOSE DESCRIBED IN THIS MANUAL MUST BE PERFORMED BY A QUALIFIED TECHNICIAN.

SPECIAL NOTES

WARNING/CAUTION notices as used in this manual apply to hazards or unsafe practices which could result in personal injury or property damage.

NOTICE

THE INFORMATION CONTAINED IN THIS DOCUMENT IS SUBJECT TO CHANGE WITHOUT NOTICE.

WHEELCHAIR USER

As a manufacturer of wheelchairs, Invacare endeavors to supply a wide variety of wheelchairs to meet many needs of the end user. However, final selection of the type of wheelchair to be used by an individual rests solely with the user and his/her healthcare professional capable of making such a selection.

WHEELCHAIR TIE-DOWN RESTRAINTS AND SEAT POSITIONING STRAPS

Invacare recommends that wheelchair users **NOT** be transported in vehicles of any kind while in wheelchairs. As of this date, the Department of Transportation has not approved any tie-down systems for transportation of a user while in a wheelchair, in a moving vehicle of any type.

It is Invacare's position that users of wheelchairs should be transferred into appropriate seating in vehicles for transportation and use be made of the restraints made available by the auto industry. Invacare cannot and does not recommend any wheelchair transportation systems.

SAVE THESE INSTRUCTIONS

TABLE OF CONTENTS

NOTE: The information in this Owner's Manual applies to the 3G STORM ARROW, STORM TORQUE SP, RANGER X and the RECLINER Wheelchairs except where specified.

TABLE OF CONTENTS

| | |
|---------------------------------------------------------------------|-----------|
| SPECIAL NOTES | 2 |
| SPECIFICATIONS | 6 |
| SECTION 1 - GENERAL GUIDELINES | 11 |
| Repair or Service Information | 11 |
| Operating Information | 11 |
| Warning/Caution Label location | 14 |
| Safety/Handling of Wheelchairs | 15 |
| SECTION 2 - SAFETY INSPECTION/TROUBLESHOOTING | 23 |
| Safety Inspection Checklist | 23 |
| Troubleshooting | 25 |
| Troubleshooting - Electrical | 25 |
| Checking battery Charge Level | 26 |
| Using hydrometer to check battery cell levels | 27 |
| SECTION 3 - FRONT RIGGINGS | 29 |
| Installing/Removing Footrests | 29 |
| Footrest Height Adjustment | 30 |
| Adjusting/Replacing Telescoping Front Rigging Support | 32 |
| Installing Adjustable Angle Flip-up Footplate Hinge | 32 |
| Installing/Adjusting the Adjustable Angle Flip-up Footplates | 33 |
| Composite/Articulating Footplate Heel Loop Replacement | 34 |
| Installing/Removing Elevating Legrests | 35 |
| Raising/Lowering Elevating Legrests and/or Adjusting Calfpads | 36 |
| SECTION 4 - ARMS | 37 |
| Installing/Removing Flip Back Armrests | 37 |
| Adjusting Flip Back Armrests | 38 |
| Adjusting Captain's Van Seat Armrests | 38 |
| SECTION 5 - POSITIONING STRAP | 40 |
| Replacing Seat Positioning Strap | 40 |
| SECTION 6 - VAN SEAT | 41 |
| Adjusting the Captain's Van Seat | 41 |

WARNING

SECTION 7 - BATTERIES 42

Installing/Removing Batteries into/from Battery Boxes 42
Disconnecting/Connecting Battery Cables 44
When to Charge Batteries 49
Charging Batteries 49
Replacing Batteries 53
Installing/Removing Battery Boxes - Group 24 Battery Base Frames 54
Installing/Removing Battery Boxes - 22nf Battery Base Frames 57

SECTION 8 - RETAINING STRAP 58

Replacing the Battery Box Retaining Strap - 22NF battery base frames 58

SECTION 9 - MOTOR LOCKS/WHEEL LOCKS/FORKS 59

Disengaging/Engaging the Motor Lock Levers 59
Using Optional Wheel Hubs 60
Installing Wheel Locks 61
Adjusting Wheel Locks 62
Adjusting Forks 64

SECTION 10 - ELECTRONICS 65

Preparing MKIV Joystick For Use 65
Repositioning MKIV Joystick 65

SECTION 11 - RECLINER 66

Recliner Operation 66
Replacing Back or Headrest Upholstery 67
Adjusting Back or Headrest Upholstery 69

LIMITED WARRANTY 71

| SPECIFICATIONS FOR ARROW | |
|-------------------------------------------------------------------------------------------------------------------------------------------------------------------------------------------------------------------|--------------------------------------------------------------------------|
| Seat Width: | Standard 12-24-inches Recliner 14 -24-inches |
| Seat Depth: | Standard 12-24-inches Recliner 14 -24-inches |
| Back Height: | Standard 12-24-inches Recliner 18-1/2 -26-inches |
| Back Angle Range: | Standard 80° to 100° Recliner 90° to 170° |
| Seat to Floor: | Standard 17-1/2 -inches Optional 19-3/4 or 21-inches |
| Overall Width of Base: (w/o joystick) | 25-inches |
| Overall Height: Standard: Minimum: Maximum: | 34-1/4-inches 34-1/4-inches 44-1/4-inches |
| Recliner Low Seat Frame: Med. Seat Frame: High Seat Frame: | 51-1/2-inches 53-3/4-inches 55-1/2 inches |
| Overall Length (without front riggings) Standard: Long Frame: | 29-1/2-inches 32-1/2-inches |
| Weight Gearless/Brushless Motor W/O GP24 Batteries: With GP24 Batteries: Shipping (approx.): 4 Pole Motor Without Batteries: With Batteries: Shipping (approx.): | 174 lbs. 278 lbs. 214 lbs. 162 lbs. 266 lbs. 202 lbs. |
| Drive Axle: | Adjustable (Non-Recliners ONLY) |
| Drive Wheels/Tires: (Foam Filled or Pneumatic) Standard: Optional: | 14 X 3-inches 14 X 4-inches |

SPECIFICATIONS

SPECIFICATIONS

| SPECIFICATIONS FOR ARROW (Continued) | | |
|-----------------------------------------------|------------------------------------------------------------------------------------------------------------------------------------------------------------------------|----------------------|
| Casters w/Precision Sealed Bearings | | |
| Semi-Pneumatic Standard: | 8 X 2-1/4-inches | |
| Option: | 6 X 2-inches (w/ shock fork) | |
| Pneumatic or Foam Filled Standard: | 8 X 2-inches | |
| Option: | 9 X 2-3/4-inches | |
| Anti-Tippers (3-inch wheels): | Standard | |
| Caster Forks: | Standard, Shock Fork (Optional) | |
| Footrests: | Telescoping Front Rigging Supports, Swing-Away (Std), Heavy Duty (Opt.), 2-in. and 4-in. longer Pivot Slide Tube (Opt) | |
| Armrests: | Flip Back, Fixed or Adjustable Height (Desk and Full Length) | |
| Seat Angle Adjustment: | Adjustable (0° to 10°) | |
| Back Angle Adjustment: | Adjustable (80° to 115° in 5° increments) | |
| Seat Cushion: | Cushion (Optional) | |
| Chair Upholstery Options: | Naugahyde and Nylon | |
| Battery requirements: | See chart on page 53 | |
| Weight Limitations: | Arrow w/ standard gearless/brushless motor - up to 300 lbs. Arrow w/ heavy duty gearless/brushless motor - up to 400 lbs. Arrow w/ 4 pole motor - up to 400 lbs. | |
| Performance | | |
| Standard Gearless/ Brushless Motor | | |
| <u>RATING</u> | <u>SPEED</u> | <u>*RANGE</u> |
| 300 LBS | UP TO 8 mph | UP TO 29 |
| **Heavy Duty Gearless/ Brushless Motor | | |
| <u>RATING</u> | <u>SPEED</u> | <u>*RANGE</u> |
| 400 LBS | UP TO 7 +/- 10% mph | UP TO 19 |
| Standard 4 Pole Motor | | |
| <u>RATING</u> | <u>SPEED</u> | <u>*RANGE</u> |
| 400 LBS | UP TO 4-1/2 mph | UP TO 19 |

*Range will vary with battery conditions, surface, terrain and operators weight.

** Force to operate motor lock lever exceeds ANSI/RESNA WC/VOL2-1998 requirements for section 14.7 paragraph 7.2d.

| SPECIFICATIONS FOR TORQUE SP | |
|--------------------------------------------------------------------------------------------------------------------------------------|----------------------------------------------------------------------------------------------------------------------|
| Seat Width: | Standard 12-22-inches Recliner 14 -22-inches |
| Seat Depth: | Standard 12-22-inches Recliner 16 -22-inches |
| Back Height: | Standard 12-24-inches Recliner 18-1/2 -26-inches |
| Back Angle Range: | Standard 80° to 100° Recliner 90° to 170° |
| Seat to Floor: | Standard 17-1/2 -inches Optional 19-3/4 or 21-inches |
| Overall Width of Base: (w/o joystick) | 25-inches |
| Overall Height: Standard: Minimum: Maximum: | 34-1/4-inches 34-1/4-inches 44-1/4-inches |
| Recliner Low Seat Frame: Med. Seat Frame: High Seat Frame: | 51-1/2-inches 53-3/4-inches 55-1/2 inches |
| Overall Length (without front riggings) Standard: Long Frame: | 29-1/2-inches 32-1/2-inches |
| Weight Model U250 TQ (4 pole motor) W/O 22NF Batteries: With 22NF Batteries: Shipping (approx.): | Model 25I-300 TQ (4 pole Motor) W/O 22NF Batteries: With 22NF Batteries: Shipping (approx.): |
| Model 25I-300 TQ (Gearless/Brushless Motor) W/O Group 24 Batteries: With Group 24 Batteries: Shipping (approx.): | Model 25I-300 TQ (4 Pole Motor) W/O Group 24 Batteries: With Group 24 Batteries: Shipping (approx.): |
| Drive Axle: | Adjustable (Non-Recliners ONLY) |
| Drive Wheels/Tires: (Foam Filled or Pneumatic) Standard: Optional: | 14 X 3-inches 14 X 4-inches |

SPECIFICATIONS

SPECIFICATIONS

| SPECIFICATIONS FOR TORQUE SP (Continued) | | |
|-------------------------------------------------|------------------------------------------------------------------------------------------------------------------------|----------------------|
| Casters w/Precision Sealed Bearings | | |
| Semi-Pneumatic Standard: | 8 X 1-1/4-inches | |
| Option: | 6 X 2-inches (w/ shock fork) | |
| Pneumatic or Foam Filled Standard: | 8 X 2-inches | |
| Option: | 9 X 2-3/4-inches | |
| Anti-Tippers (3-inch wheels): | Standard | |
| Caster Forks: | Standard, Shock Fork (Optional) | |
| Footrests: | Telescoping Front Rigging Supports, Swing-Away (Std), Heavy Duty (Opt.), 2-in. and 4-in. longer Pivot Slide Tube (Opt) | |
| Armrests: | Flip Back, Fixed or Adjustable Height (Desk and Full Length) | |
| Seat Angle Adjustment: | Adjustable (0° to 10°) | |
| Back Angle Adjustment: | Adjustable (80° to 115° in 5° increments) | |
| Seat Cushion: | Cushion (Optional) | |
| Chair Upholstery Options: | Naugahyde and Nylon | |
| Battery requirements: | See chart on page 53 | |
| Weight Limitations: | | |
| Model U250TQ | Torque SP with 4 pole motor - up to 250 lbs. | |
| Model 251-300TQ | Torque SP with 4 pole motor - 251 lbs. to 300 lbs. | |
| Model 251-300TQ | Torque SP with G/B motor - 251 lbs. to 300 lbs. | |
| Model 301-350TQ | Torque SP with 4 pole motor - 301 lbs. to 350 lbs. | |
| Performance | | |
| MODEL U250TQ | | |
| <u>RATING</u> | <u>SPEED</u> | <u>*RANGE</u> |
| 250 LBS w/ 24:1 ratio 4 pole motor | UP TO 4-1/2 mph | UP TO 19 |
| 250 LBS w/ 18:1 ratio 4 pole motor | UP TO 6-1/2 mph | UP TO 19 |
| MODEL 251-300TQ | | |
| <u>RATING</u> | <u>SPEED</u> | <u>*RANGE</u> |
| 251-300 LBS w/ G/B motor | UP TO 8 mph | UP TO 29 |
| 251-300 LBS w/ 24:1 ratio 4 pole motor | UP TO 4-1/2 mph | UP TO 19 |
| 251-300 LBS w/ 18:1 ratio 4 pole motor | UP TO 6-1/2 mph | UP TO 19 |
| MODEL 301-35TQ | | |
| <u>RATING</u> | <u>SPEED</u> | <u>*RANGE</u> |
| 301-350 LBS | UP TO 4-1/2 mph | UP TO 19 |

**Range will vary with battery conditions, surface, terrain and operators weight.*

| SPECIFICATIONS FOR RANGER X | | |
|-----------------------------------------------------------|---------------------------------|------------------------------|
| Seat Width: | Standard 12-22-inches | Recliner 14 -22-inches |
| Seat Depth: | Standard 12-22-inches | Recliner 14 -22-inches |
| Back Height: | Standard 12-24-inches | Recliner 18-1/2 -26-inches |
| Back Angle Range: | Standard 80° to 100° | Recliner 90° to 170° |
| Seat to Floor: | Standard 17-1/2 -inches | Optional 19-3/4 or 21-inches |
| Overall Width of Base: (w/o joystick) | 25-inches | |
| Overall Height: | | |
| Standard: | 34-1/4-inches | |
| Minimum: | 34-1/4-inches | |
| Maximum: | 44-1/4-inches | |
| Recliner | | |
| Low Seat Frame: | 51-1/2-inches | |
| Med. Seat Frame: | 53-3/4-inches | |
| High Seat Frame: | 55-1/2 inches | |
| Overall Length (without front riggings) | | |
| Standard: | 29-1/2-inches | |
| Long Frame: | 32-1/2-inches | |
| Weight | | |
| Gearless/Brushless Motor | | |
| W/O GP24 Batteries: | 174 lbs. | |
| With GP24Batteries: | 278 lbs. | |
| Shipping (approx.): | 214 lbs. | |
| 4 Pole Motor | | |
| Without Batteries: | 162 lbs. | |
| With Batteries: | 266 lbs. | |
| Shipping (approx.): | 202 lbs. | |
| Drive Axle: | Adjustable (Non-Recliners ONLY) | |
| Drive Wheels/Tires: (Foam Filled or Pneumatic) | | |
| Standard: | 14 X 3-inches | |
| Optional: | 14 X 4-inches | |

SPECIFICATIONS

SPECIFICATIONS

| SPECIFICATIONS FOR RANGER X (Continued) | | |
|------------------------------------------------|------------------------------------------------------------------------------------------------------------------------|----------------------|
| Casters w/Precision Sealed Bearings | | |
| Semi-Pneumatic Standard: | 8 X 2-1/4-inches | |
| Option: | 6 X 2-inches (w/ shock fork) | |
| Pneumatic or Foam Filled Standard: | 8 X 2-inches | |
| Option: | 9 X 2-3/4-inches | |
| Anti-Tippers (3-inch wheels): | Standard | |
| Caster Forks: | Standard, Shock Fork (Optional) | |
| Footrests: | Telescoping Front Rigging Supports, Swing-Away (Std), Heavy Duty (Opt.), 2-in. and 4-in. longer Pivot Slide Tube (Opt) | |
| Armrests: | Flip Back, Fixed or Adjustable Height (Desk and Full Length) | |
| Seat Angle Adjustment: | Adjustable (0° to 10°) | |
| Back Angle Adjustment: | Adjustable (80° to 115° in 5° increments) | |
| Seat Cushion: | Cushion (Optional) | |
| Chair Upholstery Options: | Naugahyde and Nylon | |
| Battery requirements: | Group 24 | |
| Weight Limitations: | Ranger X w/ standard gearless/brushless motor - up to 300 lbs. Ranger X w/ 4 pole motor - up to 300 lbs. | |
| Performance | | |
| Standard Gearless/ Brushless Motor | | |
| <u>RATING</u> | <u>SPEED</u> | <u>*RANGE</u> |
| 300 LBS | UP TO 8 mph | UP TO 29 |
| Standard 4 Pole Motor | | |
| <u>RATING</u> | <u>SPEED</u> | <u>*RANGE</u> |
| 300 LBS | UP TO 6-1/2 mph | UP TO 19 |

**Range will vary with battery conditions, surface, terrain and operators weight.*

| |
|---------------------------------------------|
| <i>This Section Includes the Following:</i> |
| <i>Repair or Service Information</i> |
| <i>Operating Information</i> |
| <i>Safety/Handling of Wheelchairs</i> |

REPAIR OR SERVICE INFORMATION

Set-up of the Electronic Control Unit is to be performed **ONLY** by individuals certified by Invacare. The final tuning adjustments of the controller may affect other activities of the wheelchair. Damage to the equipment could occur under these circumstances. If non-certified individuals perform any work on these units, the warranty is void.

OPERATING INFORMATION

GENERAL WARNINGS

Performance adjustments should only be made by professionals of the healthcare field or persons fully conversant with this process and the driver's capabilities. Incorrect settings could cause injury to the driver, bystanders, damage to the chair and to surrounding property.

After the wheelchair has been set-up, check to make sure that the wheelchair performs to the specifications entered during the set-up procedure. If the wheelchair does **NOT** perform to specifications, turn the wheelchair **OFF** immediately and reenter set-up specifications. Repeat this section until the wheelchair performs to specifications.

DO NOT operate on roads, streets or highways.

DO NOT climb, go up or down ramps or traverse slopes greater than 9°.

DO NOT attempt to move up or down an incline with water, ice or oil film.

DO NOT attempt to drive over curbs or obstacles. Doing so may cause your wheelchair to turn over and cause bodily harm or damage to the chair.

DO NOT use parts, accessories, or adapters other than those authorized by Invacare.

DO NOT leave the power button **ON** when entering or exiting your wheelchair.

DO NOT stand on the frame of the wheelchair.

DO NOT use the footplates as a platform. When getting in or out of the wheelchair, make sure that the footplates are in the upward position or swing footrests towards the outside of the chair.

ALWAYS wear your seat positioning strap.

Anti-Tippers must be used at all times. When outdoors on wet, soft ground or on gravel surfaces, anti-tippers may not provide the same level of protection against tip over. Extra caution must be observed when traversing such surfaces.

GENERAL WARNINGS**TIRE PRESSURE**

DO NOT use your wheelchair unless it has the proper tire pressure (P.S.I.). **DO NOT** overinflate the tires. Failure to follow these recommendations may cause the tire to explode and cause bodily harm. The recommended tire pressure is listed on the side wall of the tire.

ELECTRICAL**Grounding Instructions:**

DO NOT, under any circumstances, cut or remove the round grounding prong from any plug used with or for Invacare products. Some devices are equipped with three-prong (grounding) plugs for protection against possible shock hazards. Where a two-prong wall receptacle is encountered, it is the personal responsibility and obligation of the customer to contact a qualified electrician and have the two-prong receptacle replaced with a properly grounded three-prong wall receptacle in accordance with the National Electrical Code. If you must use an extension cord, use **ONLY** a three-wire extension cord having the same or higher electrical rating as the device being connected. In addition, Invacare has placed **RED/ORANGE WARNING TAGS** on some equipment. **DO NOT** remove these tags.

BATTERIES

The warranty and performance specifications contained in this manual are based on the use of deep cycle gel cell or sealed lead acid batteries. Invacare strongly recommends their use as the power source for this unit.

Carefully read battery/battery charger information prior to installing, servicing or operating your wheelchair.

RAIN TEST

INVACARE has tested its power wheelchairs in accordance with ISO 7176 "Rain Test". This provides the end user or his/her attendant sufficient time to remove his/her power wheelchair from a rain storm and retain wheelchair operation.

DO NOT leave power wheelchair in a rain storm of any kind.

DO NOT use power wheelchair in a shower.

DO NOT leave power wheelchair in a damp area for any length of time.

Direct exposure to rain or dampness will cause the chair to malfunction electrically and mechanically; may cause the chair to prematurely rust.

Check to ensure that the battery covers are secured in place, joystick boot is **NOT** torn or cracked where water can enter and that all electrical connections are secure at all times.

GENERAL WARNINGS

DO NOT use the joystick if the boot is torn or cracked. If the joystick boot becomes torn or cracked, replace **IMMEDIATELY**.

WEIGHT TRAINING

Invacare **DOES NOT** recommend the use of its wheelchairs as a weight training apparatus. Invacare wheelchairs have **NOT** been designed or tested as a seat for any kind of weight training. If occupant uses said wheelchair as a weight training apparatus, **INVACARE SHALL NOT BE LIABLE FOR BODILY INJURY AND THE WARRANTY IS VOID.**

SHIPPING TIE DOWN RESTRAINTS

Invacare recommends that wheelchair users **NOT** be transported in vehicles of any kind while in wheelchairs. As of this date, the Department of Transportation has not approved any tie-down systems for transportation of a user while in a wheelchair, in a moving vehicle of any type.

Frame end cap can only be used as a shipping tie-down point for an **UNOCCUPIED** wheelchair.

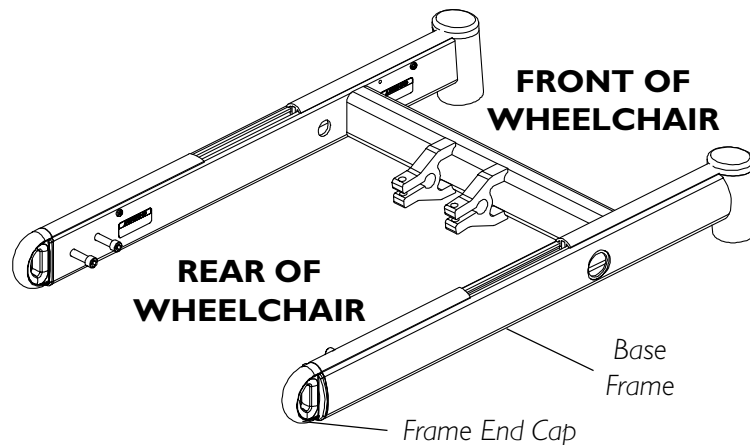

LABEL LOCATION

GENERAL GUIDELINES

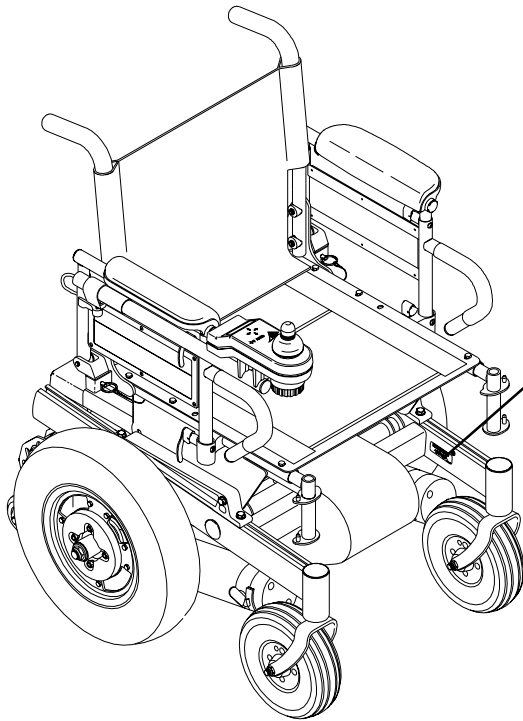

⚠ WARNING
 This stop **MUST** be in place before use. **DO NOT** remove.

NOTE: **WARNING LABEL** also found on side frame near the rear of the chair.

SUSPENSION ARM USED WITH CONVENTIONAL MOTOR/GEARBOX ASSEMBLY

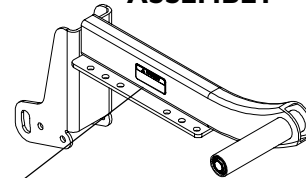

⚠ WARNING
 When using a recliner/high back van seat, the motor/gearbox or motor **MUST** use most **REARWARD** mounting holes on the suspension arm assembly.
 1053056

SUSPENSION ARM USED WITH STANDARD GEARLESS/BRUSHLESS MOTOR

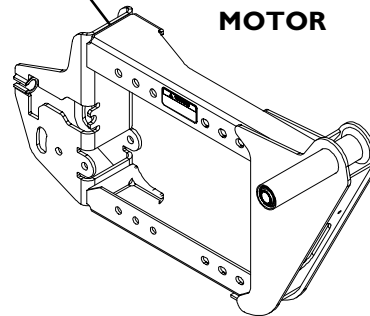

SUSPENSION ARM USED WITH HEAVY DUTY GEARLESS/BRUSHLESS MOTOR

⚠ WARNING
 Deflate tire before removing rim - otherwise serious personal injury and damage will result.
P/N 1114824 Rev A - 11/01

DRIVE PUSH
P/N 1114835

SAFETY/HANDLING OF WHEELCHAIRS

“Safety and Handling” of the wheelchair requires the close attention of the wheelchair user as well as the assistant. This manual points out the most common procedures and techniques involved in the safe operation and maintenance of the wheelchair. It is important to practice and master these safe techniques until you are comfortable in maneuvering around the frequently encountered architectural barriers.

Use this information only as a “basic” guide. The techniques that are discussed on the following pages have been used successfully by many.

Individual wheelchair users often develop skills to deal with daily living activities that may differ from those described in this manual. Invacare recognizes and encourages each individual to try what works best for him/her in overcoming architectural obstacles that they may encounter, however ALL WARNINGS and CAUTIONS given in this manual MUST be followed. Techniques in this manual are a starting point for the new wheelchair user and assistant with “safety” as the most important consideration for all.

STABILITY AND BALANCE

WARNING

ALWAYS wear your seat positioning strap.

To assure stability and proper operation of your wheelchair, you must at all times maintain proper balance. Your wheelchair has been designed to remain upright and stable during normal daily activities as long as you do not move beyond the center of gravity. DO NOT lean forward out of the wheelchair any further than the length of the armrests.

COPING WITH EVERYDAY OBSTACLES

Coping with the irritation of everyday obstacles can be alleviated somewhat by learning how to manage your wheelchair. Keep in mind your center of gravity to maintain stability and balance.

A NOTE TO WHEELCHAIR ASSISTANTS

When assistance to the wheelchair user is required, remember to use good body mechanics. Keep your back straight and bend your knees whenever tilting wheelchair or traversing curbs, or other impediments.

Also, be aware of detachable parts such as arms or leg-rests. These must NEVER be used for hand-hold or lifting supports, as they may be inadvertently released, resulting in possible injury to the user and/or assistant(s).

When learning a new assistance technique, have an experienced assistant help you before attempting it alone.

PERCENTAGE OF WEIGHT DISTRIBUTION**WARNING**

DO NOT attempt to reach objects if you have to move forward in the seat or pick them up from the floor by reaching down between your knees.

Many activities require the wheelchair user to reach, bend and transfer in and out of the wheelchair. These movements will cause a change to normal balance, center of gravity, and weight distribution of the wheelchair. To determine and establish your particular safety limits, practice bending, reaching and transferring activities in several combinations in the presence of a qualified healthcare professional **BEFORE** attempting active use of the wheelchair.

Proper positioning is essential for your safety. When reaching, leaning, bending or bending forward, it is important to use the casters as a tool to maintain stability and balance.

WARNING

When using the recliner/high back van seat, the motor/gearbox or motor **MUST** use most **REARWARD** mounting holes on the suspension arm assembly.

Changing the position of where the motors are positioned affects the weight distribution over the rear wheels. The following contains information about changing the position of the motors.

REAR POSITION - LENGTHENS the wheelbase and gives the wheelchair the most stability and standard maneuverability.

MIDDLE POSITION- CENTERS the wheelbase and gives the wheelchair standard stability and maneuverability.

FORWARD POSITION - SHORTENS the wheelbase and increases maneuverability and distributes additional weight on rear wheels.

NOTE: The FORWARD mounting position is not available on Arrow wheelchairs equipped with heavy duty gearless/brushless motors.

The following shows the positions of the screws into the gearbox:

MOTOR/GEARBOX WHEELCHAIRS

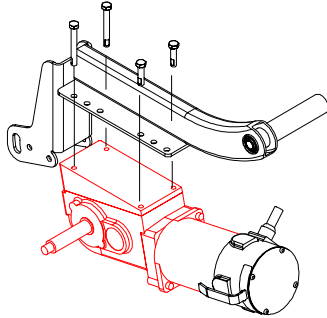

REAR POSITION -
Approximately 65%
of weight over drive
wheels

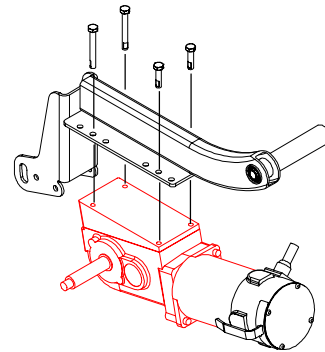

MIDDLE POSITION -
Approximately 70% of weight
over drive wheels

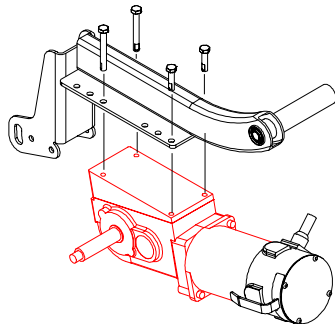

FRONT POSITION -
Approximately 75% of
weight over drive
wheels

***GEARLESS/BRUSHLESS WHEELCHAIRS**

REAR POSITION -
Approximately 65%
of weight over rear
wheels

MIDDLE POSITION
Approximately 70%
of weight over rear
wheels

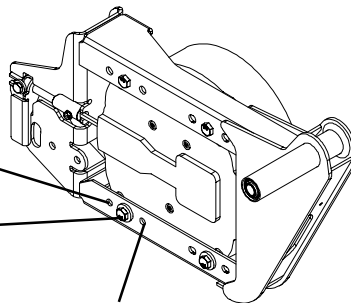

FORWARD POSITION-
Approximately 75% of weight over rear
wheels. **NOTE:** The **FORWARD**
mounting position is not available on
Arrow wheelchairs equipped with heavy
duty gearless/brushless motors.

GENERAL GUIDELINES

REACHING, LEANING, BENDING AND BENDING - FORWARD

Position the casters so that they are extended away from the drive wheels and engage wheel locks. **DO NOT ATTEMPT TO REACH OBJECTS IF YOU HAVE TO MOVE FORWARD IN THE SEAT OR PICK THEM UP FROM THE FLOOR BY REACHING DOWN BETWEEN YOUR KNEES.**

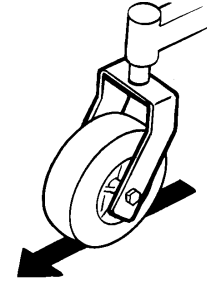

WARNING

* Inasmuch as **WHEEL LOCKS** are an **OPTION** on this wheelchair — (You may order with or without wheel locks.) — transfer to and from the wheelchair in the presence of a qualified healthcare professional to determine individual safety limits. Invacare strongly recommends ordering the wheel locks as an additional safeguard for the wheelchair user.

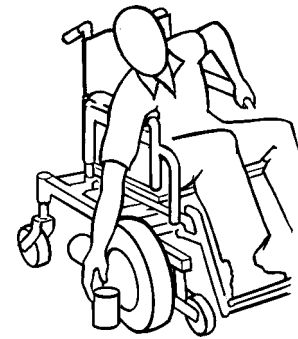

NOTE: Wheel Locks are not available on Storm chairs that have heavy duty gearless/brushless motors.

REACHING, BENDING - BACKWARD

WARNING

DO NOT lean over the top of the back upholstery. This will change your center of gravity and may cause you to tip over.

Position wheelchair as close as possible to the desired object. Position the casters so that they are extended away from the drive wheels to create the longest possible wheelbase. Reach back only as far as your arm will extend without changing your sitting position.



STAIRWAYS**WARNING**

DO NOT attempt to move an occupied power wheelchair between floors using a stairway. Use an elevator to move an occupied power wheelchair between floors. If moving a power wheelchair between floors by means of a stairway, the occupant **MUST** be removed and transported independently of the power wheelchair.

Extreme caution is advised when it is necessary to move an **UNOCCUPIED** power wheelchair up or down the stairs. Invacare recommends using two (2) assistants and making thorough preparations. Make sure to use **ONLY** secure, non-detachable parts for hand-hold supports.

DO NOT attempt to lift the wheelchair by any removable (detachable) parts. Lifting by means of any removable (detachable) parts of a wheelchair may result in injury to the user or damage to the wheelchair.

Follow these instructions for moving the wheelchair between floors when an elevator is **NOT** available:

WARNING

The weight of the wheelchair without the user and without batteries is between 154 and 278 lbs. Use proper lifting techniques (lift with your legs) to avoid injury.

1. Remove the occupant from the wheelchair.
2. Remove battery box(es) from wheelchair. Refer to INSTALLING/REMOVING BATTERY BOXES - GROUP 24 BATTERY BASE FRAMES or 22NF BATTERY BASE FRAMES in SECTION 7 of this manual.
3. Bend your knees and keep your back straight.
4. Using non-removable (non-detachable) parts of the wheelchair, lift the wheelchair off of the ground and transfer the wheelchair up or down the stairs.
5. The wheelchair should not be lowered until the last stair has been negotiated and the wheelchair has been carried away from the stairway.

ESCALATORS? SORRY!

DO NOT use an escalator to move a wheelchair between floors. Serious bodily injury may occur.

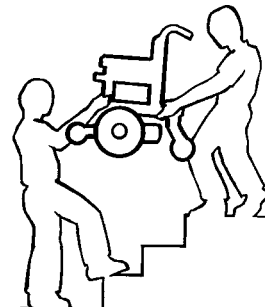

TRANSFERRING TO AND FROM OTHER SEATS**WARNING**

ALWAYS turn the wheelchair power **OFF** and engage the motor locks/ clutches to prevent the wheels from moving **BEFORE** attempting to transfer in or out of the wheelchair. Also make sure every precaution is taken to reduce the gap distance. Align both casters parallel with the object you are transferring onto.

* Inasmuch as **WHEEL LOCKS** are an **OPTION** on this wheelchair — (You may order with or without wheel locks.) — transfer to and from the wheelchair in the presence of a qualified healthcare professional to determine individual safety limits. Invacare strongly recommends ordering the wheel locks as an additional safeguard for the wheelchair user.

NOTE: Wheel Locks are not available on Storm chairs that have heavy duty gearless/brushless motors.

CAUTION

When transferring, position yourself as far back as possible in the seat. This will prevent broken screws, damaged upholstery and the possibility of the wheelchair tipping forward.

NOTE: Adequate mobility and upper body strength is required to perform this activity independently.

1. Position the wheelchair as close as possible along side the seat to which you are transferring, with the casters aligned parallel with the object.
2. Engage motor locks and wheel locks*. Refer to **DISENGAGING/ENGAGING MOTOR LOCK LEVERS** in SECTION 9 of this manual. Shift body weight into seat with transfer.
3. During independent transfer, little or no seat platform will be beneath you. Use a transfer board if at all possible.

**MINIMIZE
GAP
DISTANCE**

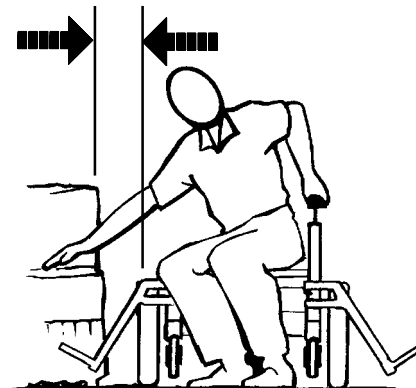

WARNING

CAUTION: IT IS VERY IMPORTANT THAT YOU READ THIS INFORMATION REGARDING THE POSSIBLE EFFECTS OF ELECTROMAGNETIC INTERFERENCE ON YOUR POWERED WHEELCHAIR.

Electromagnetic Interference (EMI) From Radio Wave sources

Powered wheelchairs and motorized scooters (in this text, both will be referred to as powered wheelchairs) may be susceptible to electromagnetic interference (EMI), which is interfering electromagnetic energy (EM) emitted from sources such as radio stations, TV stations, amateur radio (HAM) transmitters, two way radios, and cellular phones. The interference (from radio wave sources) can cause the powered wheelchair to release its brakes, move by itself, or move in unintended directions. It can also permanently damage the powered wheelchair's control system. The intensity of the interfering EM energy can be measured in volts per meter (V/m). Each powered wheelchair can resist EMI up to a certain intensity. This is called its "immunity level." The higher the immunity level, the greater the protection. At this time, current technology is capable of achieving at least a 20 V/m immunity level, which would provide useful protection from the more common sources of radiated EMI. This powered wheelchair model as shipped, with no further modification, has an unknown immunity level.

There are a number of sources of relatively intense electromagnetic fields in the everyday environment. Some of these sources are obvious and easy to avoid. Others are not apparent and exposure is unavoidable. However, we believe that by following the warnings listed below, your risk to EMI will be minimized.

The sources of radiated EMI can be broadly classified into three types:

- 1) **Hand-held Portable transceivers** (transmitters-receivers with the antenna mounted directly on the transmitting unit. Examples include: citizens band (CB) radios, "walkie talkie," security, fire and police transceivers, cellular telephones, and other personal communication devices. ****NOTE:** Some cellular telephones and similar devices transmit signals while they are ON, even when not being used
- 2) **Medium-range mobile transceivers**, such as those used in police cars, fire trucks, ambulances, and taxis. These usually have the antenna mounted on the outside of the vehicle; and
- 3) **Long-range transmitters and transceivers**, such as commercial broadcast transmitters (radio and TV broadcast antenna towers) and amateur (HAM) radios.

NOTE: Other types of hand-held devices, such as cordless phones, laptop computers, AM/FM radios, TV sets, CD players, cassette players, and small appliances, such as electric shavers and hair dryers, so far as we know, are not likely to cause EMI problems to your powered wheelchair.

WARNING**Powered Wheelchair Electromagnetic Interference (EMI)**

Because EM energy rapidly becomes more intense as one moves closer to the transmitting antenna (source), the EM fields from hand-held radio wave sources (transceivers) are of special concern. It is possible to unintentionally bring high levels of EM energy very close to the powered wheelchair's control system while using these devices. This can affect powered wheelchair movement and braking. Therefore, the warnings listed below are recommended to prevent possible interference with the control system of the powered wheelchair.

Electromagnetic interference (EMI) from sources such as radio and TV stations, amateur radio (HAM) transmitters, two-way radios, and cellular phones can affect powered wheelchairs and motorized scooters.

Following the warnings listed below should reduce the chance of unintended brake release or powered wheelchair movement which could result in serious injury.

- 1) Do not operate hand-held transceivers (transmitters receivers), such as citizens band (CB) radios, or turn ON personal communication devices, such as cellular phones, while the powered wheelchair is turned ON;
- 2) Be aware of nearby transmitters, such as radio or TV stations, and try to avoid coming close to them;
- 3) If unintended movement or brake release occurs, turn the powered wheelchair OFF as soon as it is safe;
- 4) Be aware that adding accessories or components, or modifying the powered wheelchair, may make it more susceptible to EMI (Note: There is no easy way to evaluate their effect on the overall immunity of the powered wheelchair); and
- 5) Report all incidents of unintended movement or brake release to the powered wheelchair manufacturer, and note whether there is a source of EMI nearby.

Important Information

- 1) 20 volts per meter (V/m) is a generally achievable and useful immunity level against EMI (as of May 1994) (the higher the level, the greater the protection);
- 2) The MCC MKIV controller for this application has an unknown immunity level.

Modification of any kind to the electronics of this wheelchair as manufactured by Invacare may adversely affect the RFI immunity levels.

| |
|----------------------------------------------------|
| <i>This Section Includes the Following:</i> |
| Safety Inspection Checklist |
| Troubleshooting - Mechanical/Electrical |
| Checking Battery Charge Level |
| Using Hydrometer To Check Battery Cells |

NOTE: Every six (6) months take your wheelchair to a qualified dealer for a thorough inspection and servicing. Regular cleaning will reveal loose or worn parts and enhance the smooth operation of your wheelchair. To operate properly and safely, your wheelchair must be cared for just like any other vehicle. Routine maintenance will extend the life and efficiency of your wheelchair.

SAFETY INSPECTION CHECKLIST

Initial adjustments should be made to suit personal body structure/user capability and preference. Thereafter follow these maintenance sections:

| ITEM | Initially | Inspect/ Adjust Weekly | Inspect/ Adjust Monthly | Inspect/ Adjust Periodically |
|---------------------------------------------------------------------------------------------------------------------------------------|---------------------------|------------------------------|-------------------------------|------------------------------------|
| GENERAL | | | | |
| ● Wheelchair rolls straight (no excessive drag or pull to one side). | X | | | X |
| ● Motor brushes & motor gearbox coupling (4 pole) | (Replace every 18 months) | | | X |
| CLOTHING GUARDS | | | | |
| ● Ensure all fasteners are secure. | X | | | X |
| ARMS - (SECTION 4) | | | | |
| ● Secure but easy to release; adjustment levers engage properly. | X | | | X |
| ● Adjustable height arms operate and lock securely. | X | | | X |
| ARMRESTS - (SECTION 4) | | | | |
| ● Inspect for rips in upholstery. | X | | | X |
| ● Arm rest pad sits flush against arm tube. | X | | | X |
| SEAT AND BACK UPHOLSTERY | | | | |
| ● Inspect for rips or sagging. | X | | | |
| DRIVE WHEELS | | | | |
| ● Axle nut and wheel mounting nuts are secure. | X | | X | X |
| ● No excessive side movement or binding when lifted and spun when disengaged (free-wheeling). | X | | | X |
| CASTERS | | | | |
| ● Inspect wheel/fork assembly for proper tension by spinning caster; caster should come to a gradual stop. | X | X | | |
| ● Loosen/tighten locknut if wheel wobbles noticeably or binds to a stop. | X | | X | |
| CAUTION: As with any vehicle, the wheels and tires should be checked periodically for cracks and wear, and should be replaced. | | | | |

SAFETY INSPECTION CHECKLIST

Initial adjustments should be made to suit personal body structure/user capability and preference. Thereafter follow these maintenance sections:

SAFETY INSPECTION

| ITEM | Initially | Inspect/ Adjust Weekly | Inspect/ Adjust Monthly | Inspect/ Adjust Periodically |
|-------------------------------------------------------------------------------------------------------------------------------------------------------------------------------|-------------|------------------------------|-------------------------------|------------------------------------|
| CASTER/WHEEL/FORK/HEAD TUBE ● Ensure all fasteners are secure. | X | X | | |
| WHEEL LOCKS (Optional) - (SECTION 9) ● Do not interfere with tires when rolling. ● Pivot points free of wear and looseness. ● Wheel locks easy to engage. | X X X | | X X | X |
| TIRES ● Inspect for flat spots and wear. ● If pneumatic tires check for proper inflation. | X X | X X | | |
| CAUTION: As with any vehicle, the wheels and tires should be checked periodically for cracks and wear, and should be replaced. | | | | |
| CLEANING ● Clean upholstery and armrests. | X | | | X |

TROUBLESHOOTING - MECHANICAL

| Chair Veers Left/Right | Sluggish Turn/Performance | Casters Flutter | Squeaks and Rattles | Solutions |
|------------------------|---------------------------|-----------------|---------------------|-----------------------------------------------------------|
| X | X | X | | If pneumatic, check tires for correct and equal pressure. |
| X | X | X | X | Check for loose stem nuts/bolts. |
| X | | X | | Check that casters contact ground at the same time. |

| Looseness in Chair | Chair 3 Wheels | Solutions |
|--------------------|----------------|-----------------------------------------------------------|
| X | X | If pneumatic, check tires for correct and equal pressure. |
| | | Check for loose stem nuts/bolts. |

TROUBLESHOOTING - ELECTRICAL

| SYMPTOM | PROBABLE CAUSE | SOLUTIONS |
|-----------------------------------------------------------------------------------|-----------------------------------------------------------------------------------------|----------------------------------------------------------------------------------------------------------------------------------------------------------------------------------------|
| Batteries draw excessive current when charging. | Battery failure. Electrical malfunction. | Check batteries for shorted cell. Replace if necessary (SECTION 7). Contact Dealer/Invacare for Service. |
| Battery indicator flashes the charge level is low—immediately after recharge. | Battery failure. Malfunctioning battery charger. Electrical malfunction. | Check batteries for shorted cell. Replace if necessary (SECTION 7). Contact Dealer/Invacare for Service. Poor connections between charger / wheelchair. Contact Dealer/Invacare. |
| Battery indicator flashes the charge level is low—too soon after being recharged. | Batteries not charged. Weak batteries. | Have charger checked. Replace batteries if necessary. Contact Dealer/Invacare for Service. |
| Motor “chatters” or runs irregular. | Electrical malfunction. | Contact Dealer/Invacare for Service. |
| Only one (1) drive wheel turns. | Electrical malfunction. One motor lock is disengaged. | Contact Dealer/Invacare for Service. Engage motor lock (SECTION 9). |
| Joystick erratic or does not respond as desired. | Damaged motor coupling. Electrical malfunction. Controller Programmed improperly. | Contact Dealer/Invacare for Service. Contact Dealer/Invacare for Service. Reprogram controller (Refer to MCC-MK5 controller manual supplied with wheelchair). |
| Wheelchair does not respond to commands. | Poor battery terminal connection. | Clean terminals (SECTION 7). |
| Power indicator OFF—even after recharging. | Electrical malfunction. | Contact Dealer/Invacare for Service. |

NOTE: For additional troubleshooting information and explanation of error codes, refer to the individual ELECTRONICS MANUAL supplied with each wheelchair.

NOTE: For additional troubleshooting information and explanation of electrical symptoms, refer to additional sections in this section of the manual.

CHECKING BATTERY CHARGE LEVEL

The following “Do’s” and “Don’ts” are provided for your convenience and safety.

| DON'T | DO |
|------------------------------------------------------------------------------------------------------------|-----------------------------------------------------------------------------------------------------------------------------------------|
| Don't perform any installation or maintenance without first reading this manual. | Read and understand this manual and any service information that accompanies a battery and charger before operating the wheelchair. |
| Don't perform installation or maintenance of batteries in an area that could be damaged by battery spills. | Move the wheelchair to a work area before checking the fluid level, adding distilled water, cleaning terminals, or opening battery box. |
| Don't make it a habit to discharge batteries to the lowest level. | Recharge as frequently as possible to maintain a high charge level and extend battery life. |
| Don't use randomly chosen batteries or chargers. | Follow recommendations in this manual when selecting a battery or charger. |
| Don't put new batteries into service before charging. | Fully charge a new battery before using. |
| Don't tip or tilt batteries. | Use a carrying strap to remove, move or install a battery. |
| Don't use ordinary tap water. | Don't use ordinary tap water. |
| Don't overfill cells. | ONLY use distilled water to refill. |
| Don't use uneven levels of distilled water in the cells. | Keep the liquid level in the cells at the “split ring” level. Maintain the liquid in all cells at the “split ring” level. |
| Don't tap on clamps and terminals with tools. | Push battery clamps on the terminals. Spread clamps wider if necessary. |
| Don't mismatch your battery and chargers. | Use ONLY a GEL charger for a GEL or sealed battery and a regular charger for regular batteries. |

USING HYDROMETER TO CHECK BATTERY CELLS (LEAD ACID) (FIGURE 1)

NOTE: Perform this section when a digital voltmeter is not available.

WARNING

NEVER smoke or strike a match near the batteries. If the caps of the battery cells are removed, **NEVER** look directly into them when charging the battery.

The use of rubber gloves and chemical goggles or face shields is recommended when testing the battery cells.

When reading a hydrometer, **DO NOT** allow any liquid to come in contact with your eyes or skin. It is a form of acid and can cause serious burns, and in some cases, blindness. If you do get battery acid on you, flush the exposed areas with cool water **IMMEDIATELY**. If the acid comes into contact with eyes or causes serious burns, get medical help **IMMEDIATELY**.

The battery acid can damage your wheelchair, clothing, and household items. Therefore, take readings cautiously and only in designated areas.

ONLY use distilled water when topping off the battery cells.

Most batteries are not sold with instructions. However, warnings are frequently noted on the cell caps. Read them carefully.

1. Remove the battery batteries from the wheelchair. Refer to REMOVING/INSTALLING BATTERIES in SECTION 7 of this manual.
2. Remove the battery caps from the battery.
3. Squeeze the air from the hydrometer.
4. Place the hydrometer into a battery cell.

NOTE: DO NOT fill hydrometer more than 3/4 full.

5. Draw up sufficient acid to cover float balls.
6. Tap lightly to remove air bubbles.
7. Number of floating balls indicates charge.

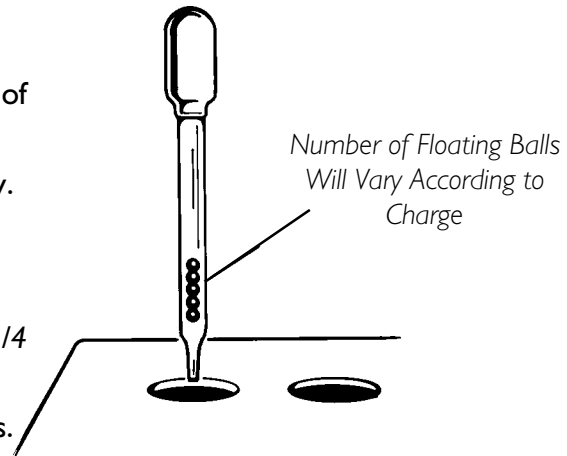

FIGURE 1 - USING A HYDROMETER TO CHECK BATTERY CELLS (LEAD ACID)

NUMBER OF FLOATING BALLS

| | |
|----|--------------|
| 0 | Discharged |
| 1 | 25% Charged |
| 2 | 50% Charged |
| 3 | 75% Charged |
| 4 | 100% Charged |
| 5* | Overcharged |

* Check charging system.

8. Flush the liquid back into the same cell after reading the float. Repeat this step until all cells have been properly read. A shorted or dead cell can be detected when it is the only cell that doesn't charge.
9. Flush the hydrometer in cold running water by allowing the water to rise into the hydrometer as far as possible. Do this several times to guard against burn damage.
10. Replace the battery caps.
11. Reinstall the batteries. Refer to REMOVING/INSTALLING BATTERIES in SECTION 7 of this manual.

This Section Includes the Following:***Installing/Removing Footrests******Footrest Height Adjustment******Adjusting/Replacing Telescoping Front******Rigging Support******Installing Adjustable Angle Flip-up Footplate Hinge******Installing/Adjusting Adjustable Angle Flip-up Footplates******Composite/Articulating Footplate Heel Loop******Replacement******Installing/Removing Elevating Legrests******Raising/Lowering Elevating Legrests and/or Adjusting Calfpads*****WARNING**

After ANY adjustments, repair or service and BEFORE use, make sure that all attaching hardware is tightened securely - otherwise injury or damage may result.

INSTALLING/REMOVING FOOTRESTS**70°/TAPER PIN STYLE (FIGURE 1)**

1. Turn the footrest to the side (open footplate is perpendicular to wheelchair).
2. Install the hinge plates on the footrest onto the hinge pins on the wheelchair frame.
3. Push the footrest towards the inside of the wheelchair until it locks into place.

NOTE: The footplate will be on the inside of the wheelchair when locked in place.

4. Repeat STEPS 1-3 for other footrest assembly.
5. To remove the footrest, push the footrest release lever inward, rotate footrest outward.
6. Refer to FOOTREST HEIGHT ADJUSTMENT in this section of the manual.

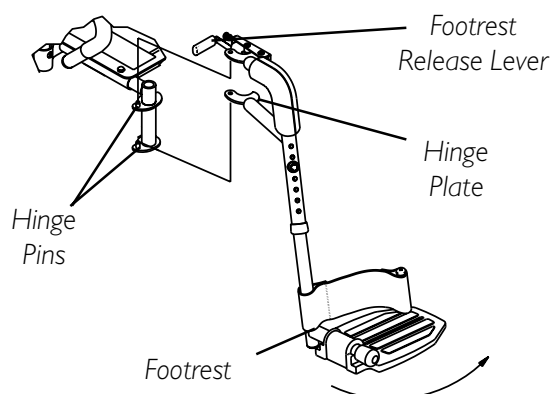

FIGURE 1 - INSTALLING/REMOVING FOOTRESTS - 70°/TAPER PIN STYLE

60°, 70°, MFX, Taper and 90° (FIGURE 2)

1. Turn the footrest to the side (open footplate is perpendicular to wheelchair itself).
2. Insert footrest mounting pin into mounting tube.
3. Push the footrest towards the inside of the wheelchair until it locks into place.

NOTE: The footplate will be on the inside of the wheelchair when locked in place.

4. Repeat STEPS 1- 3 for the other footrest assembly.
5. To remove the footrest, push the footrest release lever inward, rotate footrest outward.
6. Refer to FOOTREST HEIGHT ADJUSTMENT in this section of the manual.

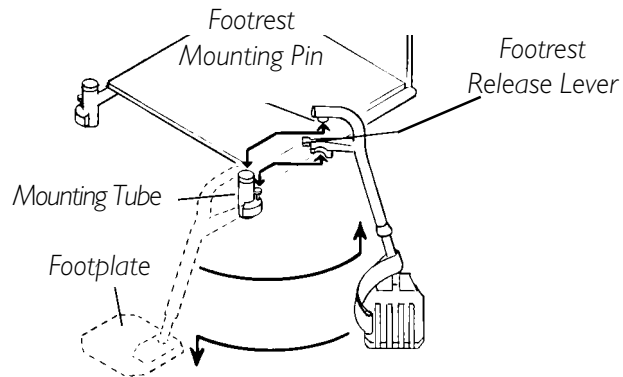

FIGURE 2 - INSTALLING/REMOVING FOOTRESTS - 60°, 70°, MFX, TAPER AND 90°

FOOTREST HEIGHT ADJUSTMENT

60°, 70°, 70° MFX, 90°, PW93, PW93E, PW93ST (FIGURE 3)

1. Remove any accessory from the footrest(s).
2. Remove the footrest from the wheelchair. Refer to INSTALLING/REMOVING FOOTRESTS in this section of the manual.

NOTE: Lay the footrest on a flat surface to simplify this section.

3. Remove the mounting screw, washers and locknut that secure the lower footrest to the footrest support.
4. Reposition the lower footrest to the desired height.
5. Reinstall the mounting, washers and locknut that secure the lower footrest to the footrest support and tighten securely.
6. Repeat STEPS 1-5 for the opposite side of the wheelchair footrest, if necessary.
7. Reinstall the footrest(s) onto the wheelchair. Refer to INSTALLING/REMOVING FOOTRESTS in this section of the manual.
8. Reinstall any accessory onto the footrest(s).

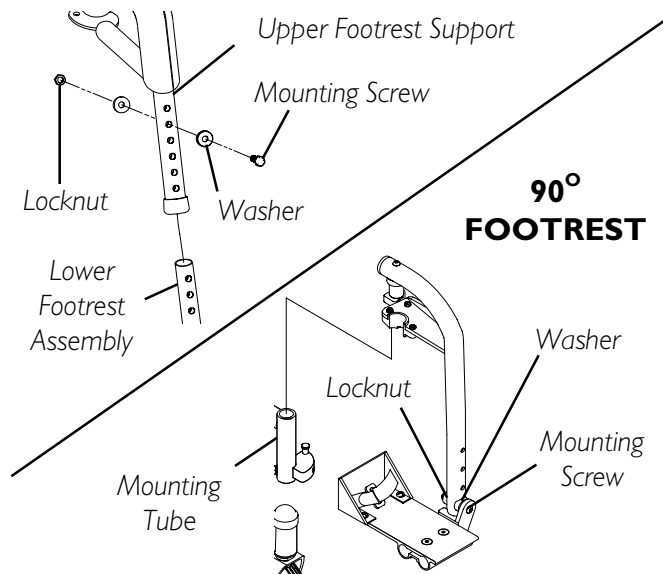

FIGURE 3 - FOOTREST HEIGHT ADJUSTMENT - 60°, 70°, 70° MFX, 90°, PW93, PW93E, PW93ST

60° MFX, 70° TAPER (FIGURE 4)

1. Remove any accessory from the footrest(s).
2. Remove the footrest from the wheelchair. Refer to INSTALLING/REMOVING FOOTRESTS in this section of the manual.

NOTE: Lay the assembly on a flat surface to simplify this section.

NOTE: Note the position of the spacers before disassembly.

3. Remove the mounting screw and coved spacer that secures the lower footrest assembly.
4. Position the footrest assembly to the desired height.
5. Secure lower footrest assembly with existing mounting screw and coved spacer. Securely tighten.

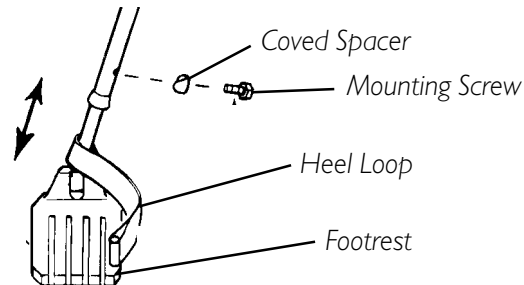

FIGURE 4 - FOOTREST HEIGHT ADJUSTMENT - 60° MFX, 70° TAPER

NOTE: Make sure spacers are positioned properly when reassembling so as not to damage the frame mounting tubes.

6. Reinstall the footrest(s) onto the wheelchair. Refer to INSTALLING/REMOVING FOOTRESTS in this section of the manual.
7. Reinstall any accessory onto the footrest(s).

PAS4A, 93M, P904A, AND PAL4A (FIGURE 5)

1. Loosen, but do not remove the lug bolt and locknut that secure the lower footrest to the footrest support.
2. Reposition the lower footrest to the desired height.
3. Securely tighten the lug bolt and locknut that secure the lower footrest to the footrest support.
4. Repeat STEPS 1-3 for the opposite side of the wheelchair footrest, if necessary.

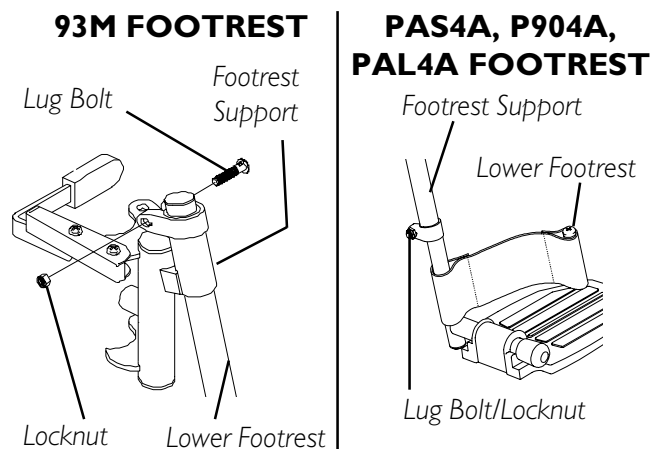

FIGURE 5 - FOOTREST HEIGHT ADJUSTMENT - PAS4A, 93M, P904A, PAL4A

ADJUSTING/REPLACING TELESCOPING FRONT RIGGING SUPPORT (FIGURE 6)

1. Remove the two (2) mounting screws, spacers and locknuts that secure the telescoping front rigging support to the seat frame.
2. Perform one (1) of the following:
 - A. Slide existing telescoping front rigging support to one (1) of three (3) depth positions.
 - B. Remove existing telescoping front rigging.
3. Secure telescoping front rigging at desired depth with existing two (2) mounting screws, spacers, and locknuts. Securely tighten.

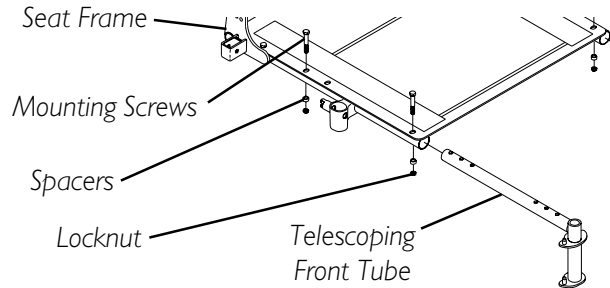

FIGURE 6 - ADJUSTING/REPLACING TELESCOPING FRONT RIGGING SUPPORT

NOTE: The two (2) telescoping front rigging supports can be positioned at different depths depending on the need of the user.

INSTALLING ADJUSTABLE ANGLE FLIP-UP FOOTPLATE HINGE (FIGURE 7)

1. Position adjustable angle flip-up footplate (**footplate**) hinge on the footrest support tube at the desired height.
2. Position mounting screw, washers, spacer, and locknut on the footrest support as shown in FIGURE 7.
3. Flip the footplate hinge to the UP position.

NOTE: The footplate hinge will fall to the DOWN position.

4. Tighten the mounting screw, washer, and locknut that secure the footplate hinge to the footrest support until the footplate hinge remains in the UP position.
5. Check the up and down motion of the footplate hinge to make sure the user of the wheelchair can operate the footplates easily.

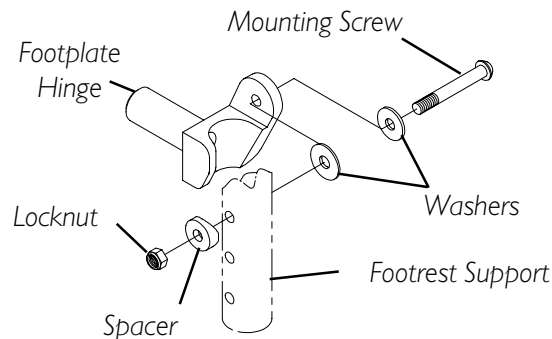

FIGURE 7 - INSTALLING ADJUSTABLE ANGLE FLIP-UP FOOTPLATE HINGE

NOTE: If footplate's motion is too tight, loosen the mounting screw and locknut approximately 1/4-turn counter clockwise.

NOTE: If the footplate's motion is too loose, tighten mounting screw and locknut approximately 1/4-turn clockwise.

- Adjust footplate. Refer to INSTALLING/ADJUSTING ADJUSTABLE ANGLE FLIP-UP FOOTPLATES in this section of the manual.

INSTALLING/ADJUSTING ADJUSTABLE ANGLE FLIP-UP FOOTPLATES

INSTALLING ADJUSTABLE ANGLE FLIP-UP FOOTPLATES (FIGURE 8)

- Slide the half clamp over the footplate hinge.
- Loosely tighten the two (2) flat screws that secure the footplate to the half clamp.
- Adjust the footplates to the necessary angle and depth for the user. Refer to ADJUSTING ADJUSTABLE FLIP-UP FOOTPLATES in this section of the manual.

ADJUSTABLE ANGLE FLIP-UP FOOTPLATE DEPTH ADJUSTMENT (FIGURE 8)

- Remove the two (2) flat screws, washers and locknuts that secure articulating footplate to the half clamp.

NOTE: Observe the angle of the articulating footplate for reinstallation.

- Move articulating footplate to one (1) of four (4) mounting positions.

NOTE: If desired depth is still not obtained, rotate the half clamp on the footplate hinge 180°.

- Retighten the two (2) flat screws, washers and locknuts.

NOTE: The settings for positioning the articulating footplates on the half-clamps may vary for each footplate.

- Refer to ADJUSTABLE ANGLE FLIP-UP FOOTPLATE ANGLE ADJUSTMENT or ADJUSTABLE ANGLE FLIP-UP FOOTPLATE PERPENDICULAR AND/OR INVERSION/EVERSION ADJUSTMENT in this section of the manual.

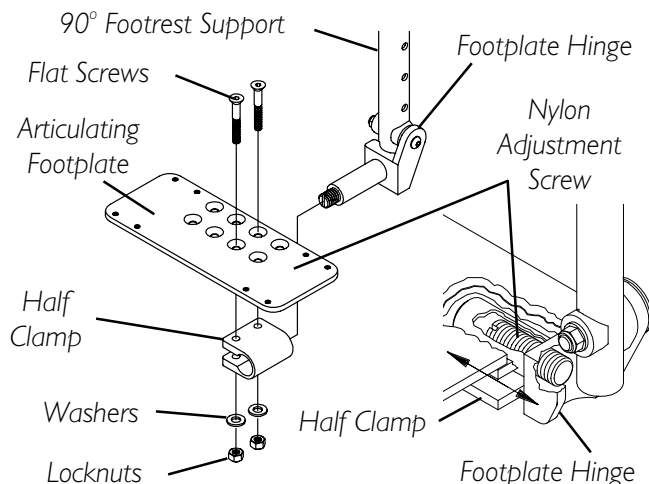

FIGURE 8 - INSTALLING/ADJUSTING ADJUSTABLE ANGLE FLIP-UP FOOTPLATES

ADJUSTABLE ANGLE FLIP-UP FOOTPLATE ANGLE ADJUSTMENT (FIGURES 8 AND 9)

1. Loosen, but do not remove the two (2) flat screws, washer and locknuts that secure the footplate to the footplate hinge.
2. Position the articulating footplate to the necessary angle to accommodate the user.
3. Retighten the two (2) flat screws, washers and locknuts.

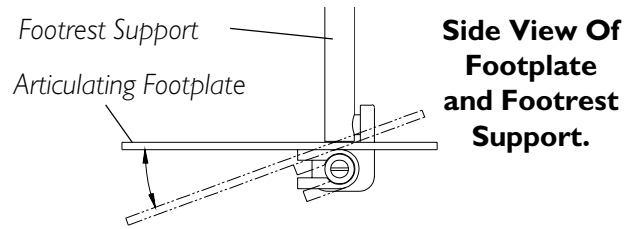

FIGURE 9 - ADJUSTABLE ANGLE FLIP-UP FOOTPLATE ANGLE ADJUSTMENT

ADJUSTABLE ANGLE FLIP-UP FOOTPLATE PERPENDICULAR AND/OR INVERSION/EVERSION ADJUSTMENT (FIGURES 8 AND 10)

NOTE: It is not necessary to remove the footplate to perform this adjustment.

1. Insert a flathead screwdriver through the half clamp on the articulating footplate.
2. Slowly turn nylon adjustment screw in or out until articulating footplate is perpendicular to the footrest assembly or the desired inversion or eversion is obtained.

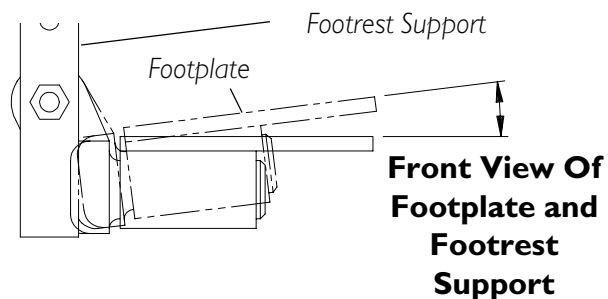

FIGURE 10 - ADJUSTABLE ANGLE FLIP-UP FOOTPLATE PERPENDICULAR AND/OR INVERSION/EVERSION ADJUSTMENT

COMPOSITE/ARTICULATING FOOTPLATE HEEL LOOP REPLACEMENT (FIGURE 11)

DISASSEMBLY

Composite.

1. Remove the mounting screw and covered washer that secures the lower half of the footrest to the swingaway footrest assembly.
2. Remove the lower footrest assembly.
3. Remove the mounting screw and locknut that secure the heel loop to the footrest.
4. Slide heel strap over cane of footrest assembly.

Articulating.

1. Remove the two (2) mounting screws that secure the heel loop to the articulating footplate.

REASSEMBLY

1. Replace heel strap/loop.
2. Reverse preceding steps to reassemble.

NOTE: When securing heel loop to the footrest assembly, tighten mounting screw until the spacer is secure.

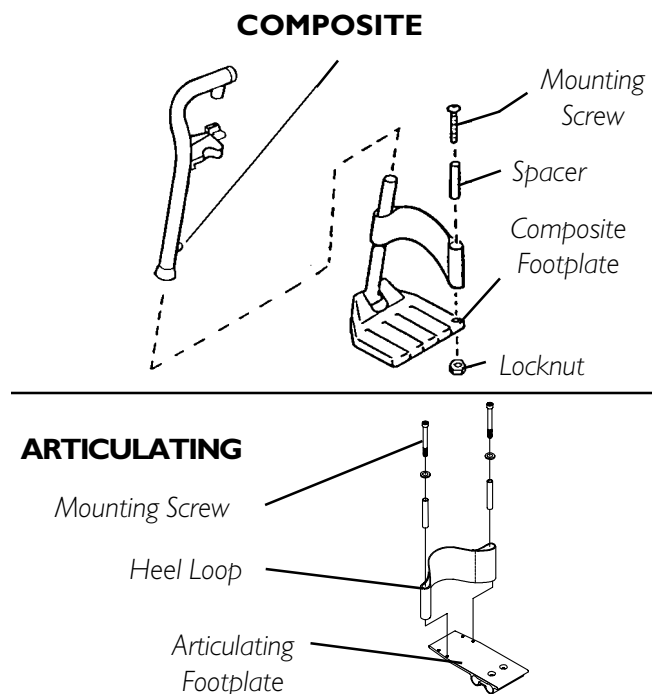

FIGURE 11 - COMPOSITE/ARTICULATING FOOTPLATE HEEL LOOP REPLACEMENT

INSTALLING/REMOVING ELEVATING LEGRESTS (FIGURE 12)

INSTALLING

1. Turn legrest to side (open footplate is perpendicular to wheelchair) and position mounting holes in the legrest hinge plates with hinge pins on the wheelchair frame.
2. Install the legrest hinge plates onto the hinge pins on the wheelchair frame.
3. Rotate legrest toward the inside of the wheelchair until it locks in place.

NOTE: The footplate will be on the inside of the wheelchair when locked in place.

4. Repeat STEPS 1-3 for the opposite legrest.
5. After seated in wheelchair, adjust footplate to correct height by loosening nut and sliding the lower footrest assembly up or down until desired height is achieved.

REMOVING

1. Push the legrest release handle toward the inside of the wheelchair (facing the front of the wheelchair) and swing the legrest to the outside of the wheelchair.
2. Lift up on the legrest and remove from the wheelchair.
3. Repeat STEPS 1- 2 for opposite side of wheelchair.

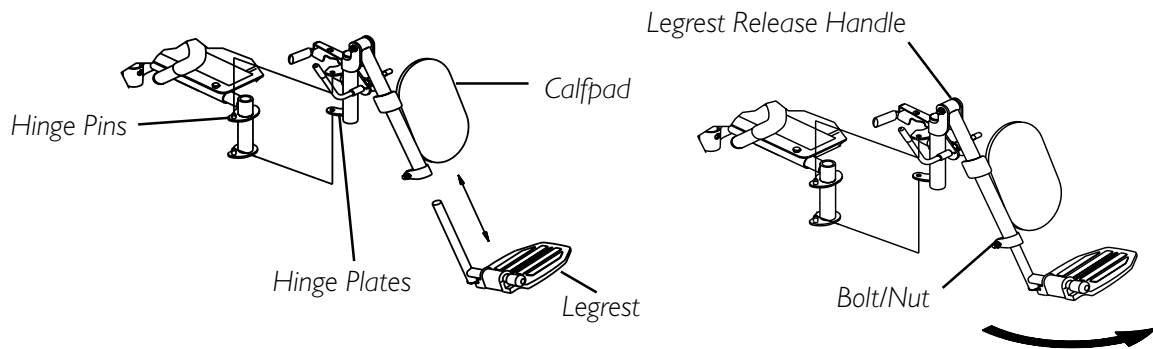

FIGURE 12 - INSTALLING/REMOVING ELEVATING LEGRESTS

RAISING/LOWERING ELEVATING LEGRESTS AND/OR ADJUSTING CALFPADS (FIGURE 13)

RAISING/LOWERING ELEVATING LEGRESTS

1. Perform one (1) of the following:

RAISING - Pull back on the release lever until the leg is at the desired height.

LOWERING - Support leg with one (1) hand and push release lever downward with other hand.

Legrest to Normal Position

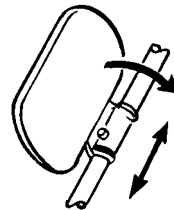
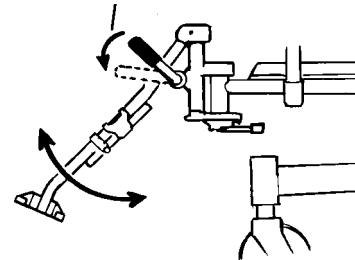

Adjust Calfpad

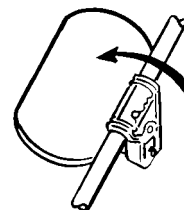

Secure Calfpad

ADJUSTING CALFPADS

1. Turn the calfpad towards the outside of the wheelchair.
2. Slide the calfpad up or down until the desired position is obtained.

NOTE: If one (1) of the top two (2) calfpad adjustment positions is being used, the legrest will need to be raised to avoid interference with the front stabilizers while going over obstacles or going up and down ramps. Refer to RAISING/LOWERING ELEVATING LEGRESTS in this section of the manual.

3. Turn the calfpad towards the inside of the wheelchair.

FIGURE 13 - RAISING/LOWERING ELEVATING LEGRESTS AND/OR ADJUSTING CALFPADS

This Section Includes the Following:

Installing/Removing Flip Back Armrests

Adjusting Flip Back Armrests

Adjusting Captain's Van Seat Armrests

WARNING

After **ANY** adjustments, repair or service and **BEFORE** use, make sure that all attaching hardware is tightened securely - otherwise injury or damage may result.

INSTALLING/REMOVING FLIP BACK ARMRESTS (FIGURE 1)

WARNING

Make sure the flip back armrest release and height adjustment levers are in the locked position before using the wheelchair.

NOTE: Flip back armrest release lever must be in the unlocked (UP- HORIZONTAL) position when placing the armrest into the arm sockets.

INSTALLING

1. Visually inspect to ensure flip back armrest release lever is in the unlocked (UP- HORIZONTAL) position.
2. Slide the flip back armrest into the arm sockets on the seat frame.
3. Install the quick release pin through the rear arm socket and flip back armrest.
4. Lock the flip back armrest by pressing the flip back armrest release lever into the DOWN (VERTICAL) position.
5. Repeat STEPS 1-4 for the opposite flip back armrest.

REMOVING

1. Unlock the flip back armrest by positioning the flip back armrest release lever into the UP (HORIZONTAL) position.
2. Remove the quick release pin that secures the flip back armrest to the rear arm socket.
3. Pull up on the flip back armrest and remove the armrest from the arm sockets.
4. Repeat STEPS 1-3 for the opposite flip back armrest, if necessary.

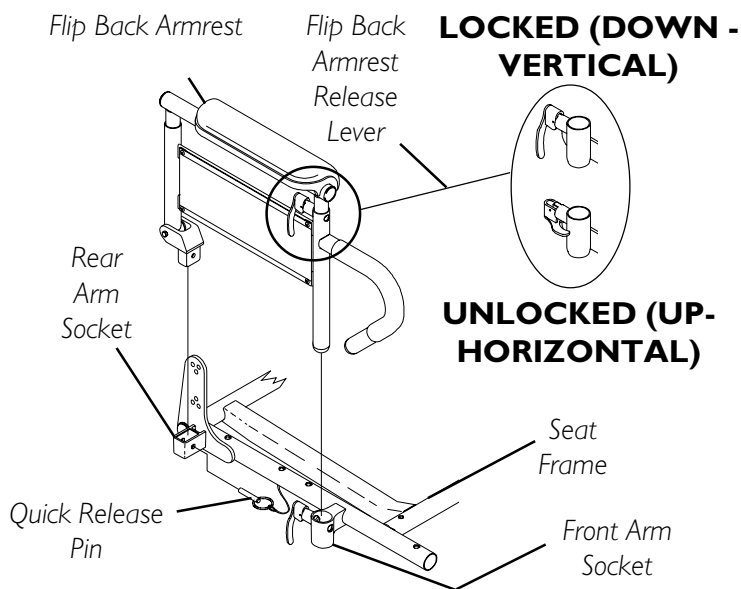

FIGURE 1 - INSTALLING/REMOVING FLIP BACK ARMRESTS

ADJUSTING FLIP BACK ARMRESTS (FIGURE 2)

WARNING

Make sure the flip back armrest release and height adjustment levers are in the locked position before using the wheelchair.

POSITIONING FLIP BACK ARMRESTS FOR USER TRANSFER

1. Unlock the flip back armrest by pulling the armrest release lever into the UP (HORIZONTAL) position.
2. Pull up on the flip back armrest and remove the armrest from the front arm socket.
3. Continue to pull up on the flip back armrest until the armrest is out of the way.
4. Repeat STEPS 1-3 for opposite flip back armrest, if necessary.

POSITIONING FLIP BACK ARMRESTS FOR USE

1. Make sure the flip back armrest release lever is in the UP (HORIZONTAL) position.
2. Install the flip back armrest into the front arm socket.
3. Lock flip back armrest by pressing flip back armrest release lever into the DOWN (VERTICAL) position.
4. Lift up on flip back armrest to make sure the armrest is locked in place.
5. Repeat STEPS 1-4 for opposite flip back armrest, if necessary.

ADJUSTING

1. Unlock top of flip back armrest by pulling height adjustment lever into the UP (HORIZONTAL) position.
2. Adjust top of the flip back armrest to the desired height.
3. Lock top of flip back armrest by pushing height adjustment lever into the DOWN (VERTICAL) position.

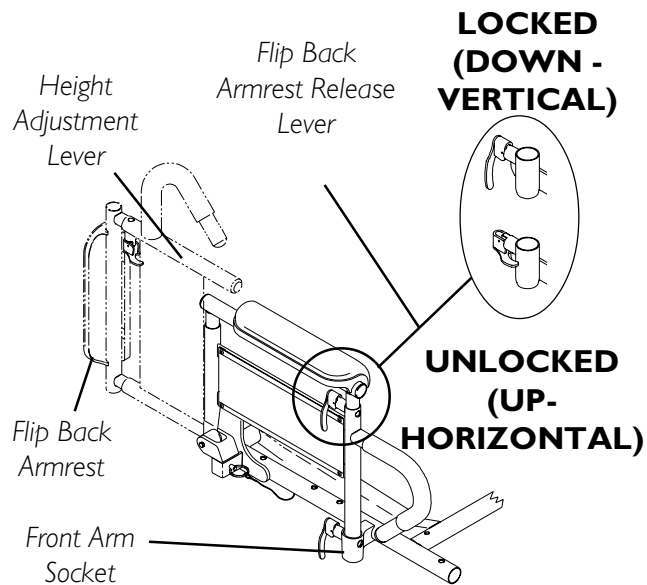

FIGURE 2 - ADJUSTING FLIP BACK ARMRESTS

ADJUSTING CAPTAIN'S VAN SEAT ARMRESTS

ANGLE (FIGURE 3)

1. Lift-up the armrest and loosen the jam nut.
2. Adjust the mounting screw up or down to the desired arm angle position.
3. Tighten the jam nut.
4. Repeat STEPS 1-3 for opposite armrest.

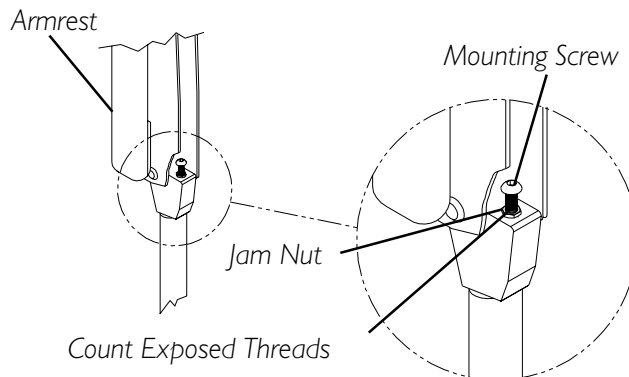

FIGURE 3 - ADJUSTING CAPTAIN'S VAN SEAT - ANGLE

NOTE: To determine the same angle for the opposite armrest, count the exposed threads after the jam nut has been tightened.

HEIGHT (FIGURE 4)

1. Remove the mounting screw that secures the armrest to the van seat frame.
2. Adjust the armrest to one (1) of four (4) positions.
3. Reinstall the mounting screw that secures the armrest to the van seat frame and tighten securely.

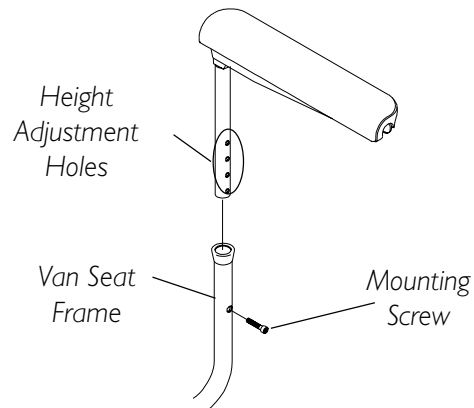

FIGURE 4 - ADJUSTING CAPTAIN'S VAN SEAT - HEIGHT

This Section Includes the Following:

Replacing Seat Positioning Strap

WARNING

After ANY adjustments, repair or service and BEFORE use, make sure that all attaching hardware is tightened securely - otherwise injury or damage may result.

REPLACING SEAT POSITIONING STRAP (FIGURE 1)

STANDARD/ADJUSTABLE SEAT FRAMES

1. Remove the seat cushion from the seat pan.
2. Move the flip back armrests out of the way. Refer to USING/ADJUSTING FLIP BACK ARMRESTS in SECTION 4 of this manual.
3. Remove the two (2) mounting screws, quick release pin tabs, spacers, and locknuts that secure the seat pan and seat positioning straps to the seat frame.
4. Remove the two (2) halves of the seat positioning strap from the rear seat frame.

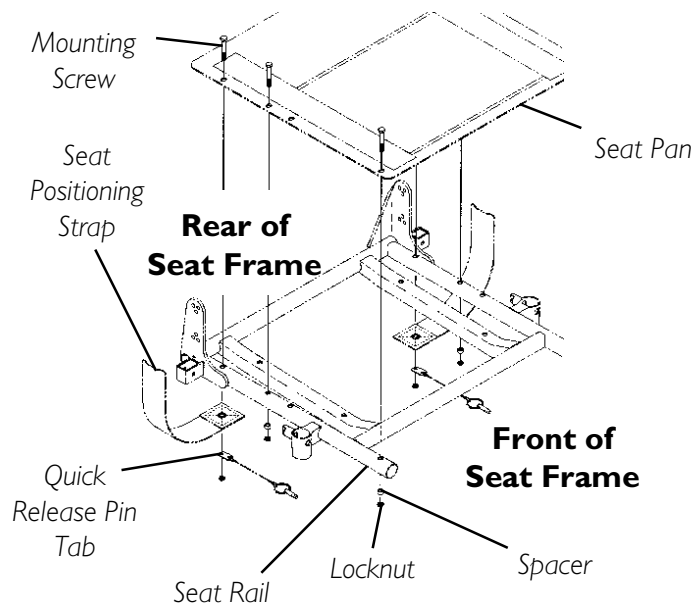

FIGURE 1 - REPLACING SEAT POSITIONING STRAP

NOTE: Quick release pin tabs are positioned underneath the seat positioning strap.

5. Reposition the two (2) NEW seat positioning strap halves underneath seat rails.
6. Reinstall the two (2) mounting screws, quick release pin tabs, spacers, and locknuts that secure the seat pan and seat positioning straps to the seat frame and torque to 75-inch pounds.
7. Reinstall the seat cushion onto the seat pan.

This Section Includes the Following:

Adjusting Captain's Van Seat

WARNING

After **ANY** adjustments, repair or service and **BEFORE** use, make sure that all attaching hardware is tightened securely - otherwise injury or damage may result.

ADJUSTING CAPTAIN'S VAN SEAT (FIGURE 1)

LOW BACK CAPTAIN'S VAN SEATS

1. Lift up on the release handle and move the back to the desired position

HIGH BACK CAPTAIN'S VAN SEATS

Angle.

WARNING

HIGH BACK CAPTAIN'S VAN SEATS ONLY

NEVER operate the wheelchair while in any recline position over **114° RELATIVE TO THE SEAT FRAME**. If the limit switch does not stop the wheelchair from operating in a recline position greater than **114° RELATIVE TO THE SEAT FRAME**, do not operate the wheelchair. Have the limit switch adjusted by an authorized Invacare dealer or qualified technician.

When using high back Captain's van seat, the motor/gearbox or motor MUST use the MOST rearward mounting holes on the suspension arm assembly.

1. Lift up on the release handle and move the back to the desired position.
2. Check the angle of the back **RELATIVE TO THE SEAT FRAME**.
3. If necessary, have the limit switch adjusted by an authorized dealer or qualified technician.

Lumbar.

1. Rotate the knob on the side of the high back Captain's Van seat **COUNTERCLOCKWISE** until the desired support is obtained.

NOTE: The knob only rotates COUNTERCLOCKWISE.

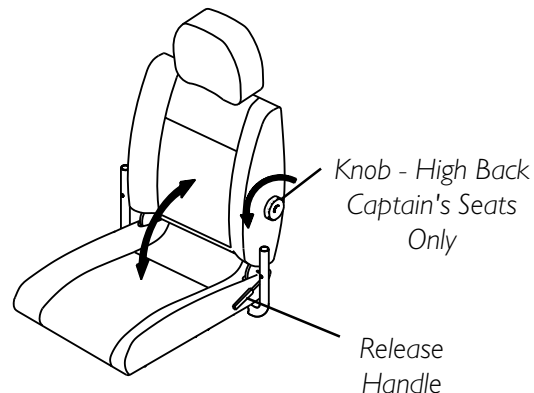

FIGURE 1 - ADJUSTING CAPTAIN'S VAN SEAT

This Section Includes the Following:

*Installing/Removing Batteries Into/From Battery Box(es)
 Disconnecting/Connecting Battery Cables
 When to Charge Batteries
 Charging Batteries
 Replacing Batteries
 Installing/Removing Battery Boxes -Group 24
 Installing/Removing Battery Boxes - 22NF*

WARNING

Make sure power to the wheelchair is **OFF** before performing this section.

The use of rubber gloves and chemical goggles or face shields is recommended when working with batteries.

Invacare strongly recommends that battery installation and battery replacement **ALWAYS** be done by a qualified technician.

After **ANY** adjustments, repair or service and **BEFORE** use, make sure all attaching hardware is tightened securely - otherwise injury or damage may result.

INSTALLING/REMOVING BATTERIES INTO/FROM BATTERY BOXES (FIGURE 1)

NOTE: To remove the battery(ies) from the battery box(es), reverse the following steps.

NOTE: Have the following tools available:

| TOOL | QTY | COMMENTS |
|----------------------------|-----|--------------|
| Battery Lifting Strap | 1 | Supplied |
| 1/2-inch (6 pt) Box Wrench | 1 | Not Supplied |

WARNING

ALWAYS use a battery lifting strap when lifting a battery. It is the most convenient method and assures that the battery acid will not spill. It also helps to prolong the life of the battery.

DO NOT tip the batteries. Keep the batteries in an upright position.

The warranty and performance specifications contained in this manual are based on the use of deep cycle gel cell or sealed lead acid batteries. Invacare strongly recommends their use as the power source for this unit.

CAUTION

Place the wheelchair in a well ventilated area where work can be performed without risking damage to carpeting or floor covering.

NOTE: If there is battery acid in the bottom or on the sides of the battery box(es) or battery(ies), apply baking soda to these areas to neutralize the battery acid. Before reinstalling the NEW or existing battery(ies), clean the baking soda from the battery box(es) or battery(ies).

NOTE: When securing battery lifting strap to battery, observe polarity markings located on the ends of the battery lifting strap, (+) side to POSITIVE (+) battery post and (-) side to NEGATIVE (-) battery post.

1. If necessary, remove the battery box(es) from the wheelchair. Refer to REMOVING/INSTALLING BATTERY BOXES - GROUP 24 BATTERY BOX BASE FRAMES or INSTALLING/REMOVING BATTERY BOX - 22NF BATTERY BASE FRAMES in this section of the manual.
2. Disconnect battery cables. Refer to DISCONNECTING/CONNECTING BATTERY CABLES for one (1) of the following:
 - A. Group 24 Batteries
 - B. 22NF batteries in single battery box
3. Secure battery lifting strap to battery terminal(s)/post(s) (FIGURE 1).

CAUTION

Some battery manufacturers mold a carrying strap and/or hold down flanges directly into the battery case. Batteries which interfere with the battery box cannot be used for these applications. Attempting to “wedge” a battery into a battery box may damage the box and/or the battery.

4. Remove batteries from battery box(es).

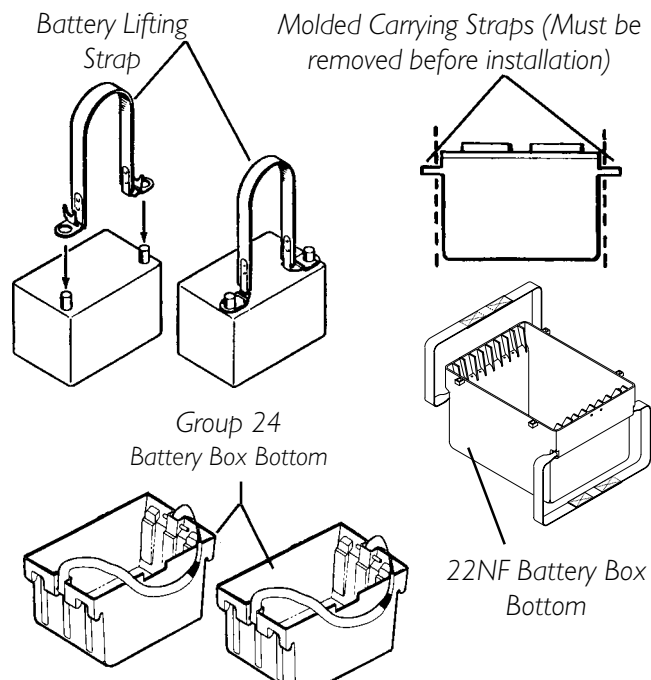

FIGURE 1 - INSTALLING/REMOVING BATTERIES INTO/FROM BATTERY BOXES

DISCONNECTING/CONNECTING BATTERY CABLES (FIGURE 2)

WARNING

NEVER allow any of your tools and/or battery cable(s) to contact **BOTH** battery post(s) at the same time. An electrical short may occur and serious personal injury or damage may occur.

The use of rubber gloves and safety glasses is recommended when working with batteries.

When tightening the clamps, always use a box wrench. Pliers will “round off” the nuts. **NEVER** wiggle the battery terminal(s)/post(s) when tightening. The battery may become damaged.

The **POSITIVE (+) RED** battery cable **MUST** connect to the **POSITIVE (+) battery terminal(s)/post(s)**, otherwise serious damage will occur to the electrical system.

GROUP 24 BATTERIES

Disconnecting.

NOTE: Perform this section on one (1) battery and battery box at a time. Repeat section for other battery box.

1. Lift up on battery box lid to expose underlying cables.
2. Peel back battery clamp covers to expose battery clamp on each battery cable as follows:
 - A. RED battery clamp cover from RED battery cable.
 - B. BLACK battery clamp cover from BLACK battery cable.
3. Disconnect NEGATIVE ^(N) battery cable clamp from NEGATIVE(-) battery post
4. Disconnect POSITIVE ^(P) battery cable clamp to POSITIVE (+) battery post (DETAIL “A”).

Connecting.

NOTE: Perform this section on one (1) battery and battery box at a time. Repeat section for other battery box.

1. Position battery box top next to battery box bottom as shown in FIGURE 2.
2. Peel back battery clamp covers to expose battery clamp on each battery cable as follows:
 - A. RED battery clamp cover from RED battery cable.
 - B. BLACK battery clamp cover from BLACK battery cable.

3. Connect NEGATIVE ^(N) battery cable clamp to NEGATIVE(-) battery post and connect POSITIVE ^(P) battery cable clamp to POSITIVE (+) battery post (DETAIL "A").
4. Secure the battery cable clamp(s) to the battery post(s) with provided hex screws and nuts. Securely tighten.
5. Verify battery cable clamps(s) are correctly installed and securely tightened.
6. Reposition battery clamp covers over battery post(s).
7. Install the battery box top(s).
8. Install the battery box(es) into the wheelchair. Refer to INSTALLING/REMOVING BATTERY BOX(ES) in this section of this manual.

NOTE: New Battery(ies) MUST be fully charged BEFORE using, otherwise the life of the battery(ies) will be reduced.

9. If necessary, charge the battery(ies). Refer to CHARGING BATTERIES in this section of the manual.

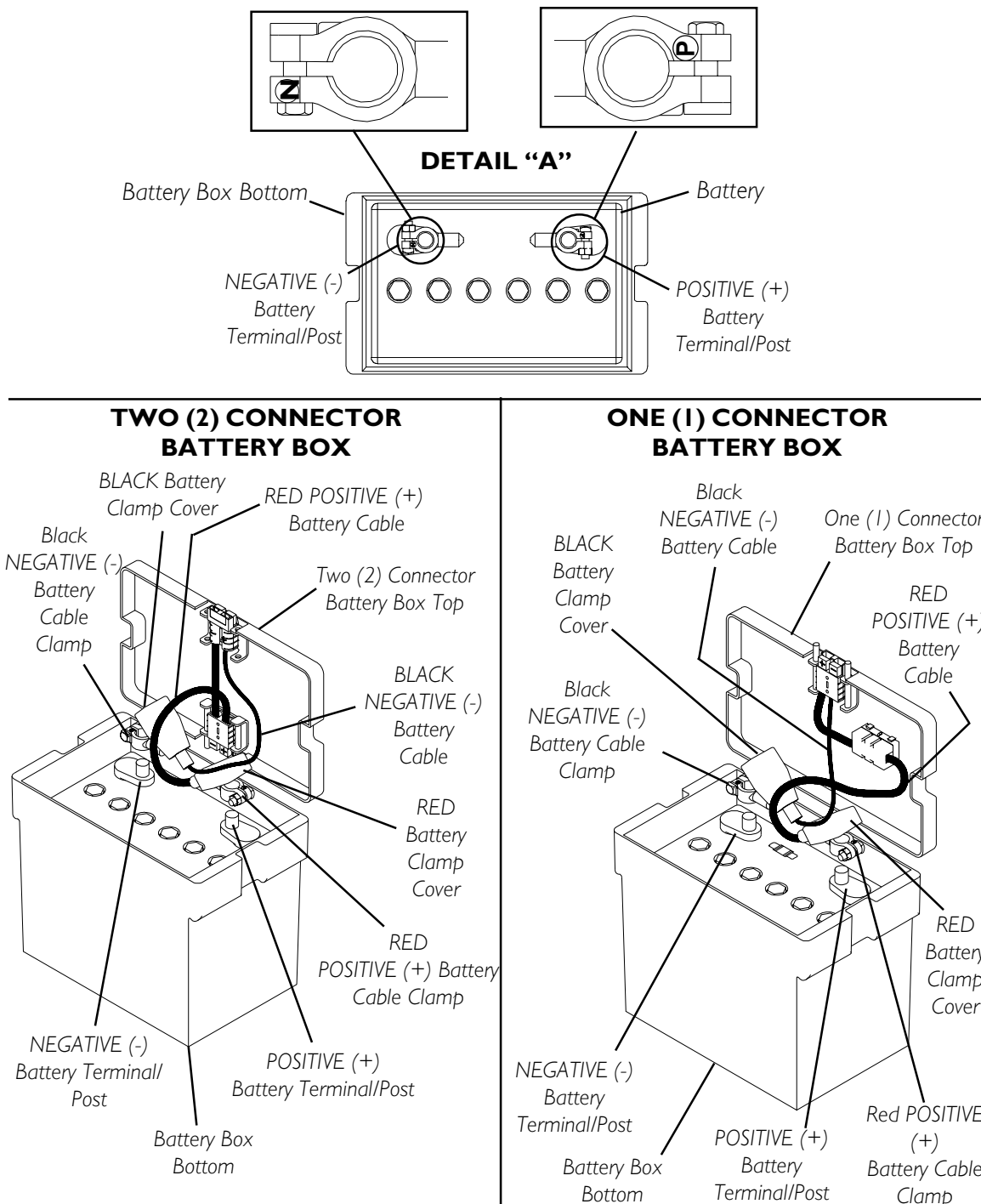

WARNING

Battery terminal polarity shown in illustration reflects the standard orientation for MK batteries. Different battery suppliers may have opposite battery terminal polarity. Always connect **NEGATIVE** battery cable clamp to **NEGATIVE(-)** battery terminal/post and **POSITIVE** battery cable clamp to **POSITIVE (+)** battery terminal/post, otherwise, injury or serious damage will occur to the electrical system.

FIGURE 2 - DISCONNECTING/CONNECTING BATTERY CABLE(S) - GROUP 24 BATTERIES

22NF BATTERIES IN SINGLE BATTERY BOX (FIGURE 3)

NOTE: Note polarity of white battery cable (jumper) battery terminal ends.

Disconnecting.

1. Remove battery terminal cap(s) from battery terminal(s) ends. Refer to DETAIL “A” in FIGURE 3.
2. Disconnect WHITE battery cable (jumper) NEGATIVE[Ⓝ] terminal end from NEGATIVE (-) battery terminal/post of front battery and disconnect POSITIVE[Ⓟ] terminal end from POSITIVE (+) battery terminal/post of rear battery.
3. Disconnect NEGATIVE (-) BLACK battery cable of the battery box top from NEGATIVE (-) battery terminal/post of rear battery.
4. Disconnect POSITIVE (+) RED battery cable on battery box top from POSITIVE (+) battery terminal/post of front battery.

Connecting.

1. Remove battery terminal cap(s) from battery terminal(s) ends. Refer to DETAIL “A” in FIGURE 3.
2. Connect WHITE battery cable (jumper) NEGATIVE[Ⓝ] terminal end to NEGATIVE (-) battery terminal/post of front battery and connect POSITIVE[Ⓟ] terminal end to POSITIVE (+) battery terminal/post of rear battery.
3. Place battery top upside down on top of rear battery.
4. Connect NEGATIVE (-) BLACK battery cable of the battery box top to NEGATIVE (-) battery terminal/post of rear battery.
5. Position battery box top right side up and rotate outward toward right to expose POSITIVE (+) battery terminal/post of front battery.
6. Connect POSITIVE (+) RED battery cable on battery box top to POSITIVE (+) battery terminal/post of front battery.
7. Replace battery terminal cap(s) onto battery cable terminal end(s).
8. Rotate top toward left into position. Secure in place.
9. Install the battery box into the wheelchair. Refer to INSTALLING/REMOVING 22NF BATTERY BOX in SECTION 7 of this manual.

NOTE: New Battery(ies) MUST be fully charged BEFORE using, otherwise the life of the battery(ies) will be reduced.

10. If necessary, charge the battery(ies). Refer to CHARGING BATTERIES in this section.

BATTERIES

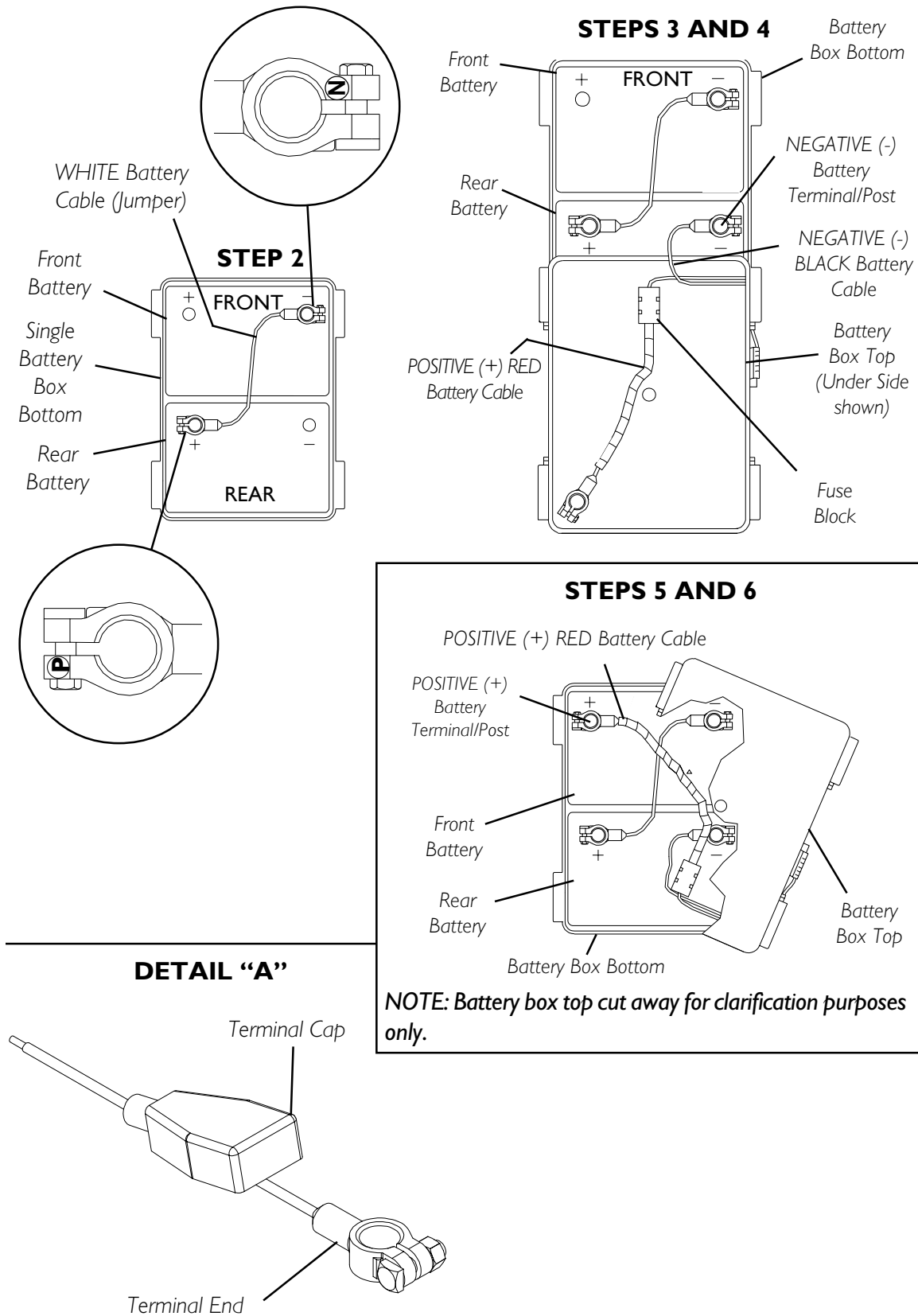

FIGURE 3 - CONNECTING BATTERY CABLES - SINGLE 22NF BATTERY BOX

WHEN TO CHARGE BATTERIES (FIGURE 4)

The Battery Discharge Indicator (BDI) is a bar graph display located on the MKIV joystick. It will keep you informed as to power availability. A visual warning is given before the power becomes too low to operate the wheelchair. At full charge the two (2) LEFT segments and the farthest RIGHT segment of the bar graph will be illuminated. As the battery becomes discharged, the farthest RIGHT segment will progressively move to the LEFT until only the last two (2) bars (LEFT) are illuminated. At this level the last two (2) bars (LEFT) will start to Flash ON and OFF to indicate that the end user should charge the batteries as soon as possible.

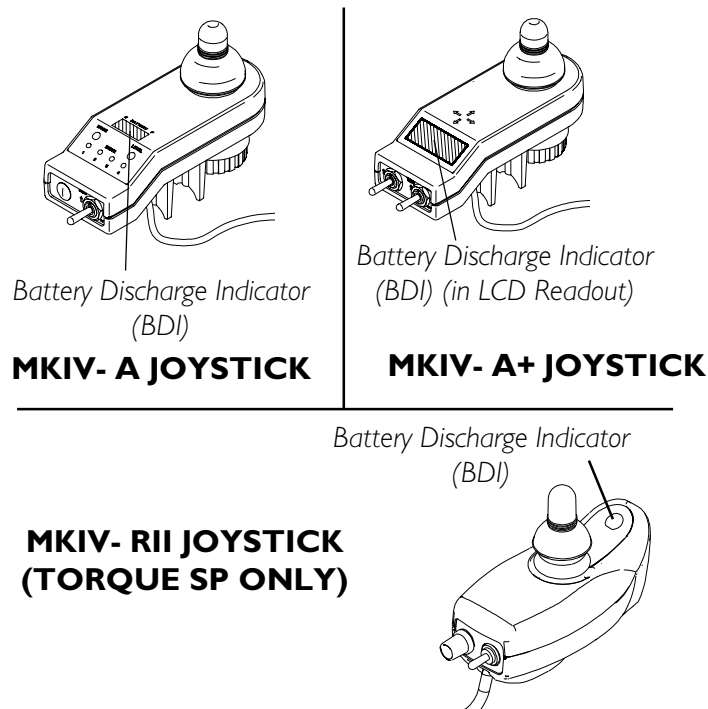

FIGURE 4 - WHEN TO CHARGE BATTERIES

CHARGING BATTERIES (FIGURE 5)

NOTE: New batteries MUST be fully charged prior to initial use of the wheelchair.

WARNING

Never attempt to recharge the batteries by attaching cables directly to the battery terminals or clamps. Always use the recharging plug located on the side of the wheelchair frame.

DO NOT attempt to recharge the batteries and operate the power wheelchair at the same time.

During use and charging, unsealed batteries will vent hydrogen gas which is explosive in the right concentration with air.

CAUTION

Always charge new batteries before initial use or battery life will be reduced.

NOTE: As a general rule, batteries should be recharged daily to assure the longest possible life and minimize the required charging time. Plan to recharge the batteries when it is anticipated the wheelchair will not be used for a long period of time.

The range per battery charge using recommended batteries should be approximately 5 to 9 hours of typical operation. Extensive use on inclines may substantially reduce per charge mileage.

DESCRIPTION AND USE OF BATTERY CHARGERS

The charger automatically reduces the charge from an initially high rate to a zero reading at a fully charged condition. If left unattended, the charger should automatically shut-off when full charge is obtained.

There are some basic concepts which will help you understand this automatic process. They are:

The amount of electrical current drawn within a given time to charge a battery is called the “charge rate”. If, due to usage, the charge stored in the battery is low, the charge rate is high, as indicated by the green light on the charger. Initially, the green light will stay illuminated for a short period of time followed by a longer period of off time. As a charge builds up, the charge rate is reduced, and the green light will stay illuminated for a longer period of time followed by a shorter off time.

WARNING

NEVER leave the charger unattended when the charger circuit breaker is tripping ON and OFF. A condition between the battery charger and batteries exists. Contact an Invacare dealer.

NOTE: If performing the charging sections independently, READ and CAREFULLY follow the individual instructions for each charger (supplied or purchased).

NOTE: If charging instructions are not supplied, consult a qualified service technician for proper instructions.

REQUIRED ITEMS:

| TOOL | QUANTITY | COMMENTS |
|------------------|----------|--------------|
| Battery Charger | 1 | Supplied |
| ◆ Extension Cord | 1 | Not Supplied |

- ◆ (3-prong plug, 15 ampere current rating; industrial type)

1. Perform one (1) of the following:

A. WHEELCHAIRS EQUIPPED WITH MCC-MARK IV JOYSTICK -

Attach the battery charger connector to the charger cable/battery harness.

NOTE: The battery charger connector is factory installed on the RIGHT side of the wheelchair. It can be positioned on either side of the wheelchair for user convenience.

NOTE FOR RECLINERS ONLY: If the wheelchair is a recliner, the battery charger connector as well as the limit switch, are factory set on the RIGHT side of the wheelchair. However, they can be positioned on either side for user convenience. The limit switch MUST BE positioned on the same side as the battery charger connector.

B. TORQUE SP EQUIPPED WITH MARK IV RII JOYSTICK- Attach the battery charger connector to the charger port on the FRONT of the joystick.

2. Plug the charger's AC power cord, or extension, into the grounded 120 VAC wall outlet.

3. Wait until charging is complete.

NOTE: Allow eight (8) hours for normal charging. Larger batteries (greater than 55 ampere-hours) or severely discharged batteries may require up to sixteen (16) hours to be properly charged and equalized. If charger operates for sixteen (16) hours and is unable to fully charge the batteries, an internal timer turns the charger off and begins to fast blink the green light.

NOTE: It is advantageous to recharge frequently rather than only when necessary. In fact, a battery's life is extended if the charge level is maintained well above a low condition.

NOTE: If the batteries need to be charged more often or take longer to charge than normal, they may need to be replaced. Contact an Invacare dealer for service.

BATTERIES

WHEELCHAIRS EQUIPPED WITH MCC-MARK IV JOYSTICK

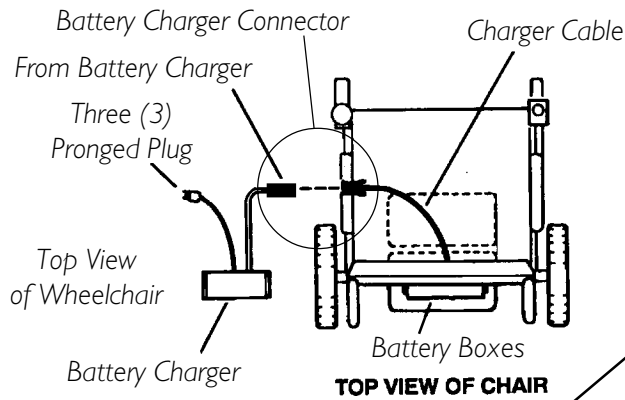

Front View of Joystick

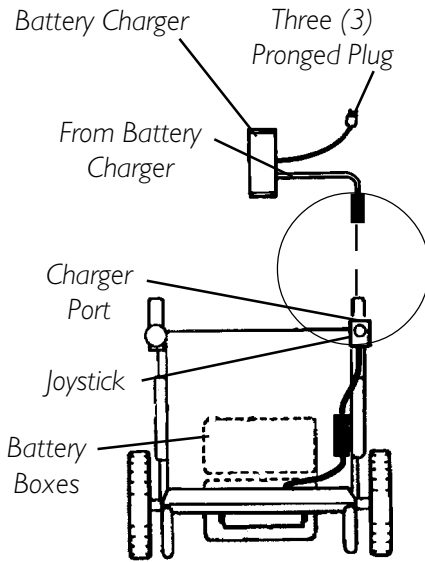
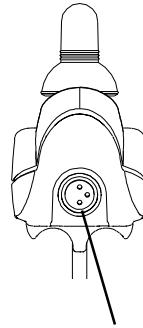

WHEELCHAIRS EQUIPPED WITH MARK IV RII JOYSTICK

NOTE: This joystick is available only on the Torque SP.

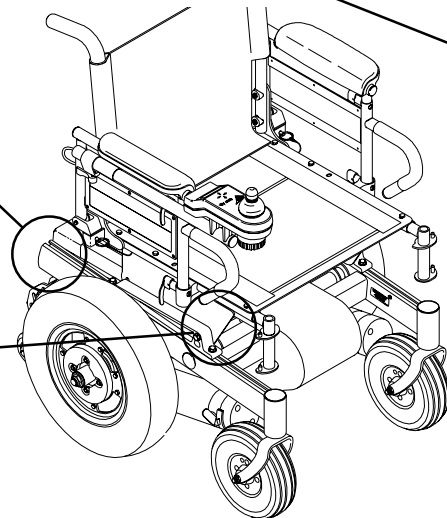
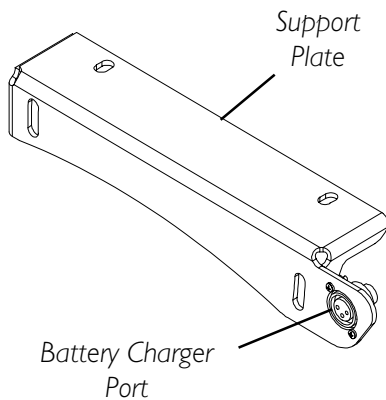
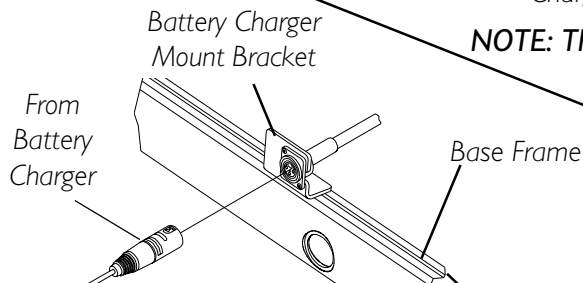

FIGURE 5 - CHARGING BATTERIES

REPLACING BATTERIES

NOTE: Invacare recommends that both batteries be replaced if one (1) battery is defective.

RECOMMENDED BATTERY TYPES

WARNING

Failure to use the correct battery size and/or voltage may cause damage to your wheelchair and give you unsatisfactory performance.

The warranty and performance specifications contained in this manual are based on the use of deep cycle gel cell or sealed lead acid batteries. Invacare strongly recommends their use as the power source for this unit.

NOTE: G/B denotes gearless/brushless. Both battery sizes are deep cycle batteries.

NOTE: Charge batteries daily. It is critical not to let them run low at any time.

1. Remove the battery box(es) from the wheelchair. Refer to INSTALLING/REMOVING BATTERY BOXES in this section of the manual.
2. Remove existing batteries from the battery box(es). Refer to INSTALLING/REMOVING BATTERIES INTO/FROM BATTERY BOX(ES) in this section of manual.
3. Clean the new battery terminals. Refer to CLEANING BATTERY TERMINALS in this section of the manual.
4. Install the new batteries into the battery box(es). Refer to INSTALLING/REMOVING BATTERIES INTO/FROM BATTERY BOX(ES) in this section of the manual.

BATTERY REQUIREMENTS AND WEIGHT LIMITATIONS

| MODEL | WEIGHT LIMITATION | MOTOR | BATTERY |
|------------------|-------------------|-------------------------------|----------|
| ARROW | Up to 300 lbs | Standard Gearless/Brushless | Group 24 |
| | Up to 400 lbs | 4 Pole Motor | Group 24 |
| | Up to 400 lbs | Heavy Duty Gearless/Brushless | Group 24 |
| TORQUE SP | Up to 250 lbs | 4 Pole Motor | *22NF |
| | 251-300 lbs | 4 Pole Motor | *22NF |
| | | Gearless/Brushless | Group 24 |
| | 301-350 lbs | 4 Pole Motor | Group 24 |
| RANGER | Up to 300 lbs. | 4 Pole Motor | Group 24 |
| | | Gearless/Brushless | Group 24 |

* Two batteries inside one battery box.

NOTE: Weight limitation is total weight: user weight plus any additional items that the user may require (back pack, etc.). (Example: If weight limitation of the chair is 300 lbs. and additional items equal 25 lbs. subtract 25 lbs from 300 lbs. This gives the maximum weight limitation of the user to be 275 lbs.)

CLEANING BATTERY TERMINALS

WARNING

Most batteries are not sold with instructions. However, warnings are frequently noted on the cell caps. Read them carefully.

DO NOT allow the liquid in the battery to come in contact with skin, clothes or other possessions. It is a form of acid and harmful or damaging burns may result. Should the liquid touch your skin, wash the area **IMMEDIATELY** and thoroughly with cool water. In serious cases or if eye contact is made, seek medical attention **IMMEDIATELY**.

1. Examine battery clamps and terminals for corrosion.
2. Verify the plastic caps are in place over battery cell holes.
3. Clean terminals and inside battery clamps by using a battery cleaning tool, wire brush, or medium grade sand paper.

NOTE: Upon completion, areas should be shiny, not dull.

4. Carefully dust off all metal particles.

REMOVING/INSTALLING GROUP 24 BATTERY BOXES FOR WHEELCHAIRS NOT EQUIPPED WITH VENT TRAY (FIGURE 6)

WARNING

Each battery weighs 51 pounds. Use proper lifting techniques (lift with your legs) to avoid injury.

CAUTION

Place the wheelchair in a well ventilated area where work can be performed without risking damage to carpeting or floor covering.

REMOVING

1. Place the wheelchair in a well ventilated area where work can be performed without risking damage to carpeting or floor covering.
2. Verify the joystick ON/OFF switch is in the OFF position.
3. Rotate the levers of the battery retainer assembly to the unlocked position.
4. Lift battery retainer assembly up off the mounting screws that secure the shocks to the base frame.

NOTE: For gearless/brushless motors, ensure that the motor lock levers are in the engaged (drive) position. Refer to SECTION 9.

5. Slide one (1) connector battery box along the sub-frame and remove from the wheelchair.
6. Slide the two (2) connector battery box along the sub-frame and remove from the wheelchair.

INSTALLING

1. Place the wheelchair in a well ventilated area where work can be performed without risking damage to carpeting or floor covering.
2. Verify the joystick ON/OFF switch is in the OFF position.
3. Secure the battery box carrying strap to the lid of the two (2) connector battery box.
4. Place two (2) connector battery box onto the battery sub-frame assembly with guide pins facing the inside of the wheelchair.
5. Slide the two (2) connector battery box along the sub-frame until its guide pins are engaged in the sub-frame connector.

NOTE: Visually inspect to ensure the connection is properly made. Connectors MUST be fully engaged.

NOTE: Make certain that the battery box carrying strap is positioned on top of the battery box and will not interfere with the one (1) battery box guide pins when engaging the connector on the one (1) battery box lid.

6. Secure the battery box carrying strap to the lid of the one (1) connector battery box.
7. Place one (1) connector battery box onto battery sub-frame.
8. Slide one (1) connector battery box along the sub-frame until its guide pins are engaged in the connector of the two (2) connector battery box.

NOTE: Visually inspect to ensure the connection is properly made. Connectors MUST be fully engaged.

9. Place the battery retainer assembly on head portion of the mounting screws that secure the shocks to the base frame.

CAUTION

The battery retainer assembly MUST be locked securely to hold the battery boxes firmly in place or battery box connectors may be damaged causing erratic wheelchair operation.

10. Rotate the levers of the battery retainer assembly to the locked position.

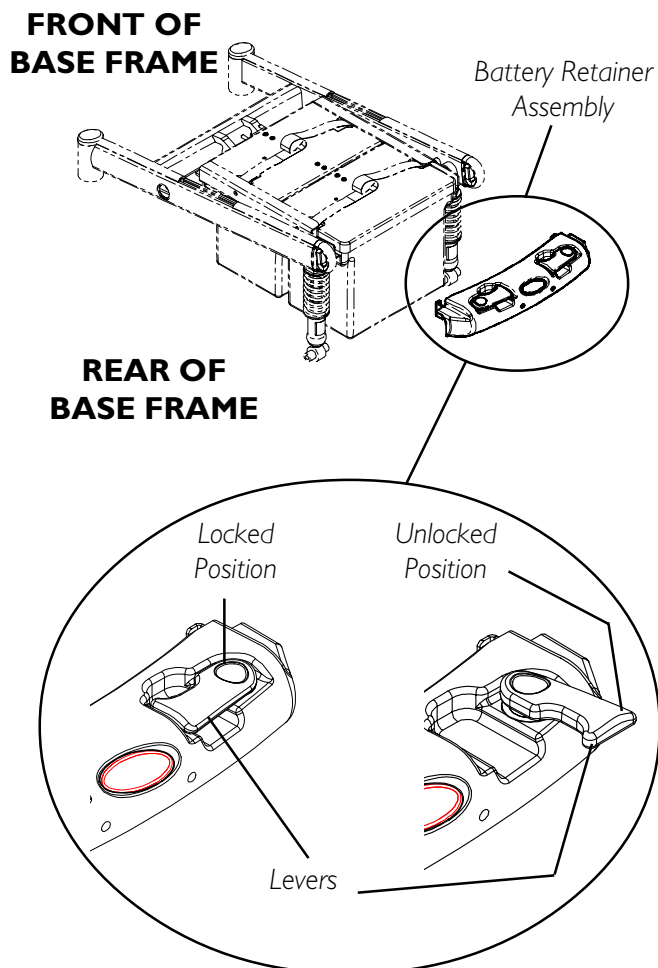

FIGURE 6 - REMOVING/INSTALLING GROUP 24 BATTERY BOXES FOR WHEELCHAIRS WITHOUT VENT TRAY

REMOVING/INSTALLING GROUP 24 BATTERY BOXES FOR WHEELCHAIRS EQUIPPED WITH VENT TRAY (FIGURE 7)

WARNING

Each battery weighs 51 pounds. Use proper lifting techniques (lift with your legs) to avoid injury.

CAUTION

Place the wheelchair in a well ventilated area where work can be performed without risking damage to carpeting or floor covering.

REMOVING

1. Place the wheelchair in a well ventilated area where work can be performed without risking damage to carpeting or floor covering.
2. Verify the joystick ON/OFF switch is in the OFF position.
3. Pull the battery box retainer UP over the end of the one (1) connector battery box.
4. Slide one (1) connector battery box along the sub-frame and remove from the wheelchair.
5. Slide the two (2) connector battery box along the sub-frame and remove from the wheelchair.

INSTALLING

1. Place the wheelchair in a well ventilated area where work can be performed without risking damage to carpeting or floor covering.
2. Verify the joystick ON/OFF switch is in the OFF position.
3. Secure the battery box carrying strap to the lid of the two (2) connector battery box.
4. Place two (2) connector battery box onto the battery sub-frame assembly with guide pins facing the inside of the wheelchair.
5. Slide the two (2) connector battery box along the sub-frame until its guide pins are engaged in the sub-frame connector.

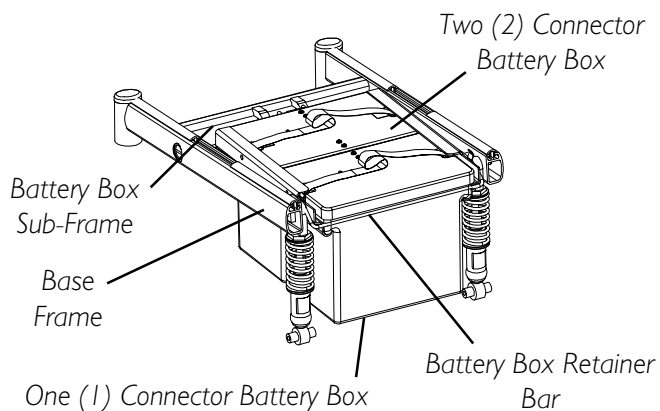
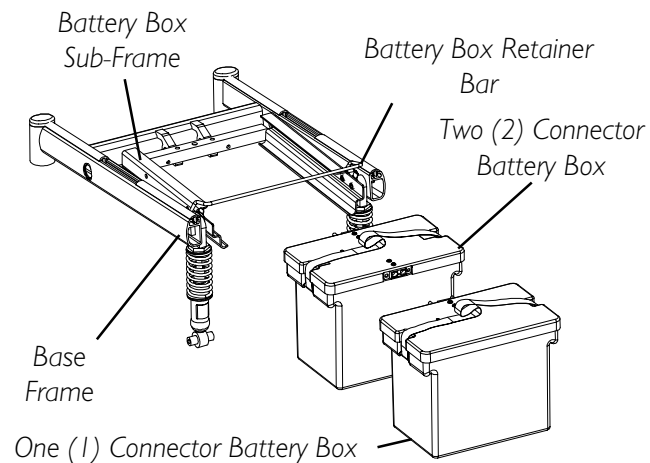

FIGURE 7 - INSTALLING/REMOVING GROUP 24 BATTERY BOXES FOR WHEELCHAIRS EQUIPPED WITH VENT TRAY

NOTE: Visually inspect to ensure the connection is properly made. Connectors MUST be fully engaged.

NOTE: Make certain that the battery box carrying strap is positioned on top of the battery box and will not interfere with the one (1) battery box guide pins when engaging the connector on the one (1) battery box lid.

6. Secure the battery box carrying strap to the lid of the one (1) connector battery box.
7. Place one (1) connector battery box onto battery sub-frame.
8. Slide one (1) connector battery box along the sub-frame until its guide pins are engaged in the connector of the two (2) connector battery box.

NOTE: Visually inspect to ensure the connection is properly made. Connectors MUST be fully engaged.

CAUTION

The battery box retainer MUST be locked securely to hold the battery boxes firmly in place or battery box connectors may be damaged causing erratic wheelchair operation.

9. Pull the battery box retainer down over the end of the one (1) connector battery box until it is securely clipped (locked) into place.

INSTALLING/REMOVING BATTERY BOX - 22NF BATTERY BASE FRAMES (FIGURE 7)

NOTE: To install the battery box onto the wheelchair, reverse the following steps.

1. Place the wheelchair in a well ventilated area where work can be performed without risking damage to carpeting or floor covering.
2. Verify the joystick ON/OFF switch is in the OFF position.
3. Disconnect the battery cable from the outside of the battery box.
4. Disconnect the battery box retention strap.
5. Remove the battery box.
6. Slide the four (4) clips that secure the battery box cover to the battery box to the OPEN position.

NOTE: Arrows on the battery box cover point to the open position.

7. Remove battery box cover from the battery box.

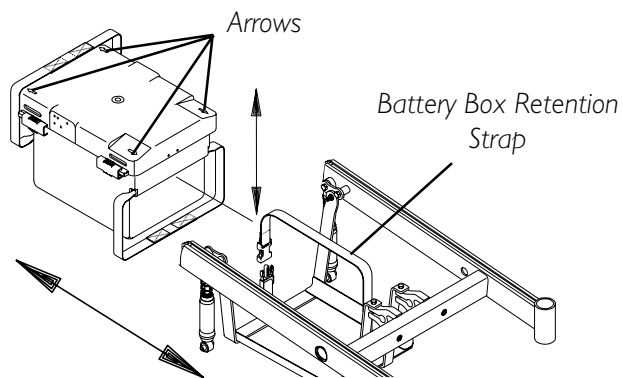

FIGURE 7 - INSTALLING/REMOVING BATTERY BOX - 22NF BATTERY BASE FRAMES

This Section Includes the Following:

Replacing Battery Box Retaining Strap - 22NF Battery Base Frames

WARNING

After ANY adjustments, repair or service and BEFORE use, make sure that all attaching hardware is tightened securely - otherwise injury or damage may result.

REPLACING BATTERY BOX RETAINING STRAP - 22NF BATTERY BASE FRAMES (FIGURE 1)

1. Remove the battery box. Refer to INSTALLING/REMOVING BATTERY BOX/BATTERIES - 22NF BATTERY BASE FRAMES in SECTION 7 of this manual.

WARNING

The retaining strap **MUST** be fed through the adjustable end of the battery box retaining strap clip as shown in **FIGURE 1**.

2. Feed the battery box retaining strap through the adjustable end of the battery box retaining strap clip.
3. Feed the battery box retaining strap through the slots in the battery box tray.

NOTE: The folded over portion of the retaining strap stops at the slot. DO NOT try to force the folded over section through the slot.

4. Install the NEW battery box retaining strap by reversing STEPS 2 and 3.
5. Reinstall the battery box. Refer to INSTALLING/REMOVING BATTERY BOX/BATTERIES - 22NF BATTERY BASE FRAMES in SECTION 7 of this manual.

WARNING

The Battery Box Retaining Strap **MUST** be fastened securely in place before using the wheelchair.

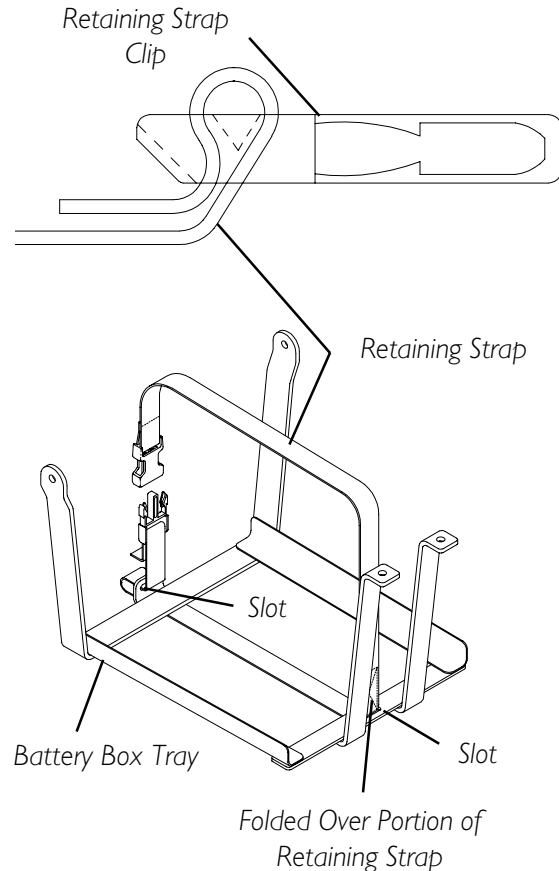

NOTE: Tray shown by itself for clarity. There is no need to remove the tray from the wheelchair if the strap is being replaced.

FIGURE 1 - REPLACING BATTERY BOX RETAINING STRAP - 22NF BATTERY BASE FRAMES

This Section includes the following:

Disengaging/Engaging Motor Lock Levers

Using Optional Wheel Hubs

Installing Wheel Locks

Adjusting Wheel Locks

Adjusting Forks

WARNING

After ANY adjustments, repair or service and BEFORE use, make sure that all attaching hardware is tightened securely - otherwise injury or damage may result.

CAUTION

As with any vehicle, the wheels and tires should be checked periodically for cracks and wear, and should be replaced.

DISENGAGING/ENGAGING MOTOR LOCK levers

WARNING

DO NOT engage or disengage motor locks until the power is in the **OFF** position.

NOTE: Motor lock disengagement/engagement allows free wheeling or joystick controlled operation. Free wheeling allows an assistant to maneuver the wheelchair without power.

4 POLE MOTORS (FIGURE 1)

1. Perform one (1) of the following:

DISENGAGE (PUSH) - push motor lock levers downward.

ENGAGE (DRIVE) - pull motor lock levers upward

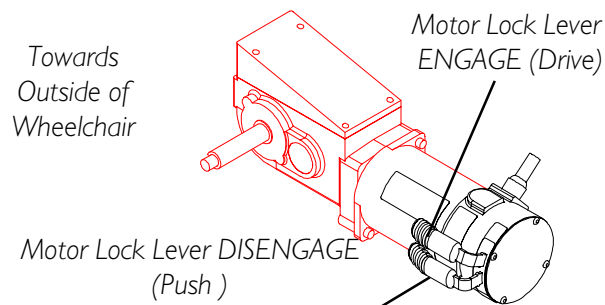

FIGURE 1 - DISENGAGING/ENGAGING MOTOR LOCK LEVERS - MOTOR/GEARBOX ASSEMBLY

STANDARD GEARLESS/BRUSHLESS MOTORS (FIGURE 2)

- I. Perform one (1) of the following: (DETAIL "A")

DISENGAGE (FREE WHEEL) - pull motor lock lever into UP position.

ENGAGE (DRIVE) - push motor lock lever into down position.

HEAVY DUTY GEARLESS/BRUSHLESS MOTORS (FIGURE 2)

- I. Perform one (1) of the following: (DETAIL "B")

ENGAGE (DRIVE) - Pull motor lock lever into UP position.

DISENGAGE (PUSH) - Push motor lock lever into DOWN position.

*NOTE: Effort to engage/disengage motor lock levers is 25 to 30 pounds.**

** NOTE - Force to operate motor lock lever exceeds ANSI/RESNA WC/VOL2-1998 requirements for section 14.7 paragraph 7.2d.*

DETAIL "A"

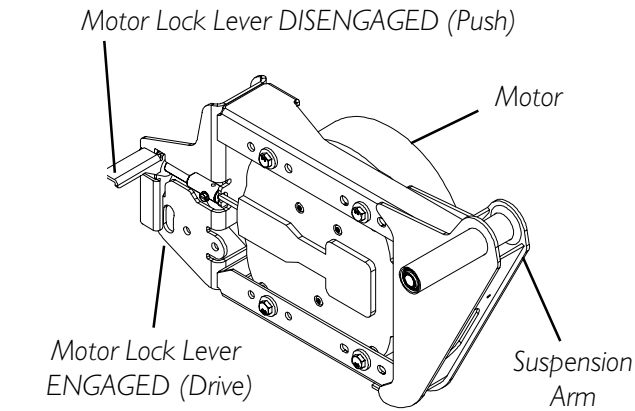

DETAIL "B"

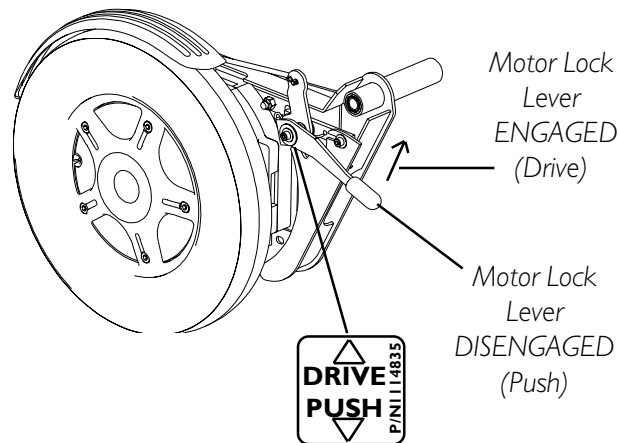

**FIGURE 2 - DISENGAGING/ENGAGING
MOTOR LOCK LEVERS - GEARLESS/
BRUSHLESS MOTORS**

USING OPTIONAL WHEEL HUBS (FIGURE 3)

NOTE: Wheel hubs are not available on Heavy Duty Gearless/Brushless motors.

- I. Perform one (1) of the following:

DISENGAGE (FREE WHEEL) - pull OUT on engagement knob and rotate engagement knob approximately 1/6-turn until the pins on the engagement knob fall into the free wheel detents on the wheel hub.(DETAIL "A")

NOTE: If the pins on the engagement knob are not in the free wheel detents, the engagement knobs can engage the motors unexpectedly while the wheelchair is being pushed.

ENGAGE (DRIVE) - pull OUT on engagement knob and rotate engagement knob approximately 1/6-turn until the pins on the engagement knob fall into the holes in the wheel hub and axle sleeve. Gently rock the wheelchair until the engagement knob snaps into place.(DETAIL "B")

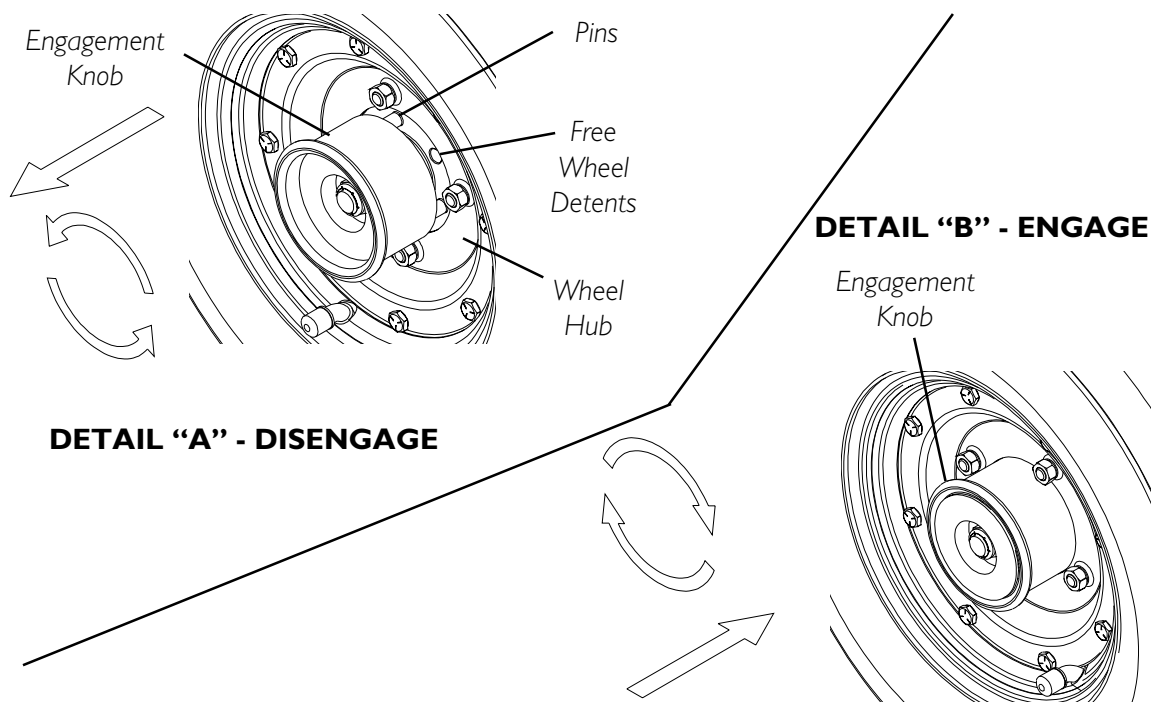

FIGURE 3 - USING OPTIONAL WHEEL HUBS-

INSTALLING *WHEEL LOCKS

NOTE: Wheel locks are not available on Heavy Duty Gearless/Brushless motors.

WARNING

***Inasmuch as WHEEL LOCKS are an OPTION on this wheelchair - (You may order with or without the wheel locks.) - transfer to and from the wheelchair in the presence of a qualified healthcare professional to determine individual safety limits. Invacare strongly recommends ordering the wheel locks as an additional safeguard for the wheelchair user.**

WHEEL LOCK INSTALLATION IDENTIFICATION (FIGURE 4)

- I. Refer to FIGURE 5 and perform one (1) of the following:
 - A. Motor assembly resembles DETAIL "A". Refer to INSTALLING WHEEL LOCKS FOR MOTOR/GEARBOX ASSEMBLIES in this section of the manual.
 - B. Motor assembly resembles DETAIL "B". Refer to INSTALLING WHEEL LOCKS FOR GEARLESS/BRUSHLESS MOTOR ASSEMBLIES in this section of the manual.

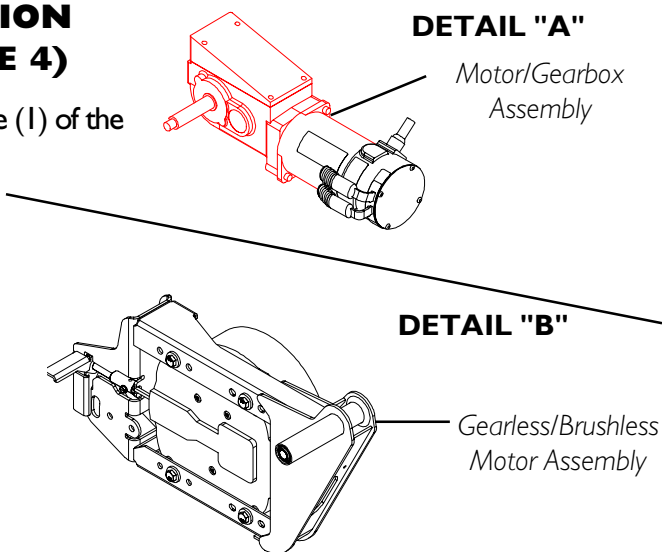

FIGURE 4 - WHEEL LOCK INSTALLATION IDENTIFICATION

INSTALLING WHEEL LOCKS FOR MOTOR/GEARBOX ASSEMBLIES (FIGURE 5)

NOTE: Refer to DETAIL "C" in FIGURE 5 for proper positioning of wheel locks.

1. Position the wheel lock on the **OUTSIDE** of the wheel lock mounting bracket and the wheel lock link on the **INSIDE** of the wheel lock bracket.
2. Loosely assemble the wheel lock and wheel lock link to the wheel lock mounting bracket with the two (2) mounting screws provided.

NOTE: The two (2) mounting screws will screw into the wheel lock link.

3. Repeat STEPS 1-2 for the opposite wheel lock.
4. Adjust the wheel locks. Refer to **ADJUSTING WHEEL LOCKS** in this section of the manual.

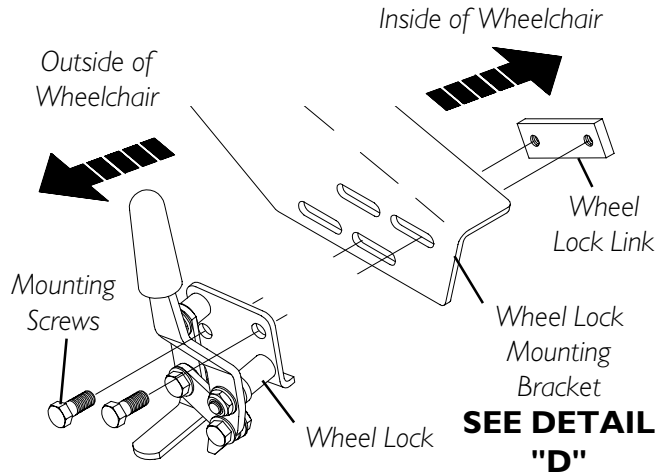
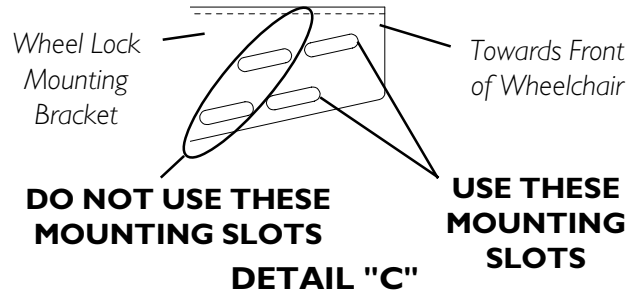

FIGURE 5 - INSTALLING WHEEL LOCKS FOR MOTOR/GEARBOX ASSEMBLIES

INSTALLING WHEEL LOCKS FOR STANDARD GEARLESS/BRUSHLESS MOTOR ASSEMBLIES (FIGURE 6)

NOTE: Wheel locks are not available on Heavy Duty Gearless/Brushless motors.

1. Position the wheel lock on the **OUTSIDE** of the suspension arm and the spotweld nut on the **INSIDE** of the suspension arm as shown in FIGURE 6.
2. Loosely assemble the wheel lock and spotweld nut to the suspension arm with the two (2) mounting screws provided using the two side holes as shown in FIGURE 6.

NOTE: The The two (2) mounting screws will screw into the spotweld nut.

3. Repeat STEPS 1-2 for opposite wheel lock.

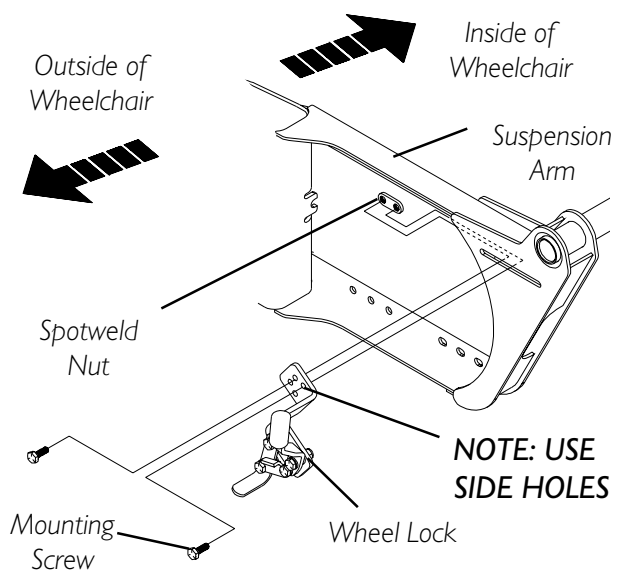

FIGURE 6 - INSTALLING WHEEL LOCKS FOR STANDARD GEARLESS/BRUSHLESS MOTOR ASSEMBLIES

4. Adjust the wheel locks. Refer to ADJUSTING WHEEL LOCKS in this section of the manual.

ADJUSTING WHEEL LOCKS (FIGURE 7)

1. Make sure wheel lock is disengaged from drive wheel.
2. Measure distance between the **WHEEL LOCK SHOE** and the **DRIVE WHEEL**.
3. Perform one (1) of the following:

MOTOR/GEARBOX WHEEL LOCKS

- A. Loosen the wheel lock from the wheel lock mounting bracket.
- B. Slide the wheel lock along the slots in the wheel lock mounting bracket until the measurement is between $5/32$ and $5/16$ -inches. Securely tighten mounting screws.
- C. Repeat STEPS 1-3 for the opposite wheel lock.

GEARLESS/BRUSHLESS MOTOR WHEEL LOCKS

- A. Loosen wheel lock from the suspension arm.
 - B. Slide the wheel lock along the slot in the suspension arm until the measurement is between $5/32$ and $5/16$ -inches. Securely tighten mounting screws.
 - C. Repeat STEPS 1-3 for the opposite wheel lock.
4. Disengage motor locks. Refer to DISENGAGING/ENGAGING MOTOR LOCKS in this section of the manual.
 5. Engage the wheel locks and push against the wheelchair to determine if the wheel locks engage the drive wheels enough to hold the wheelchair.
 6. Repeat STEPS 2-5 until the wheel locks engage the drive wheels enough to hold the wheelchair.
 7. Engage motor locks. Refer to DISENGAGING/ENGAGING MOTOR LOCKS in this section of the manual.

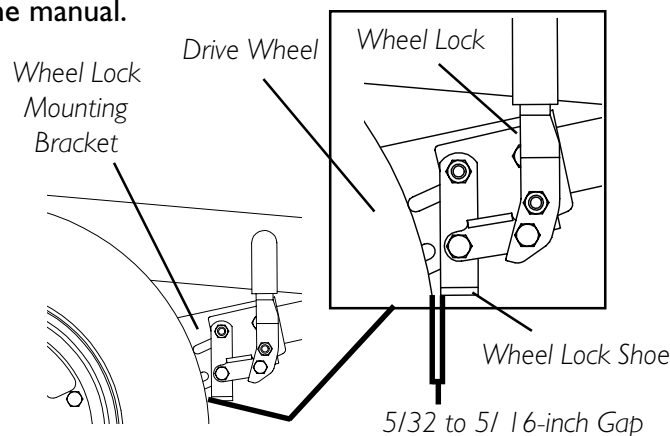

NOTE: Illustration depicts wheel lock for motor/gearbox assembly. Wheel locks adjust in the same manner for the gearless/brushless motor assembly.

FIGURE 7 - ADJUSTING WHEEL LOCKS

ADJUSTING FORKS (FIGURE 8)

1. Remove the dust cover (not shown) from the caster headtube.
2. To properly tighten caster journal system and guard against flutter, perform the following check:
 - A. Tip back the wheelchair to floor.
 - B. Pivot both forks and casters to top of their arc simultaneously.
 - C. Let casters drop to bottom of arc (wheels should swing once to one-side, then immediately rest in a straight downward position).
 - D. Adjust locknuts according to freedom of caster swing.
3. Test wheelchair for maneuverability.
4. Readjust locknuts if necessary, and repeat STEPS 1-3 until correct.
5. Snap dust cover into the caster headtube.

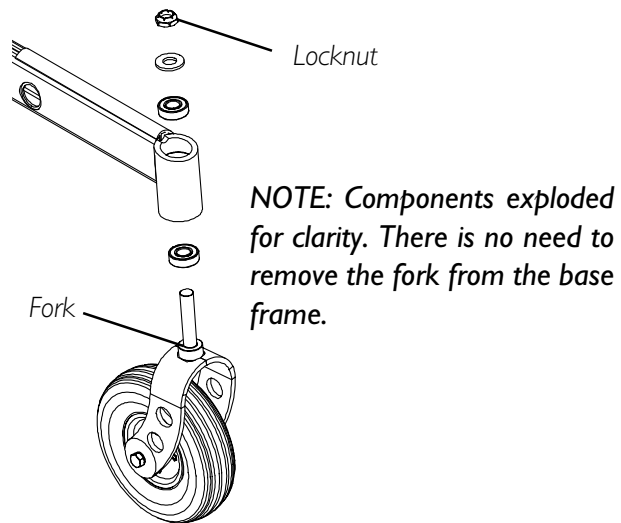

FIGURE 8 - ADJUSTING FORKS

This Section Includes the Following:

Preparing MKIV Joystick for Use

Repositioning MKIV Joystick

PREPARING MKIV JOYSTICK FOR USE (FIGURE 1)

NOTE: The MKIV joystick is factory installed on the right side of the wheelchair. To reposition the MKIV joystick onto the left side of the wheelchair, refer to REPOSITIONING MKIV JOYSTICK in this section of the manual.

1. Turn the adjustment lock lever to release the adjustment lock from joystick mounting tube.
2. Slide joystick mounting tube to the desired position.
3. Turn the adjustment lock lever to secure the adjustment lock to the joystick mounting tube.

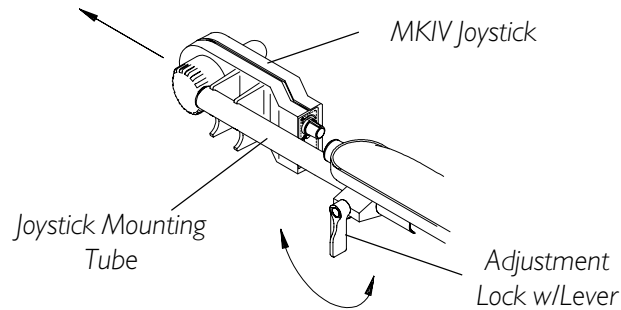

FIGURE 1 - PREPARING MKIV JOYSTICK FOR USE

REPOSITIONING MKIV JOYSTICK (FIGURE 2)

STANDARD/ADJUSTABLE SEAT MODELS

1. Turn the adjustment lock lever to release the adjustment lock from joystick mounting tube (**tube**) (FIGURE 1).
2. Remove the joystick mounting tube from wheelchair.
3. Remove the three (3) hex screws that secure the joystick mounting bracket (**bracket**), threaded hole half clamp and opened hole half clamp to the arm tube.
4. Reposition the threaded hole half clamp and opened hole half clamp on the opposite arm tube. Make sure the threaded hole half clamp is on the inside of the arm tube.
5. While holding the two (2) half clamps, install the front hex screw into the two (2) half clamps and securely tighten.
6. Line up the mounting holes of the joystick mounting bracket with the mounting holes in the two (2) half clamps.
7. Secure the joystick mounting bracket to the two (2) half clamps with the remaining two (2) hex screws.
8. Slide the tube through the bracket to the desired position.
9. Slide the adjustment lock over the end of the tube and secure the adjustment lock to the tube by turning the adjustment lock lever.

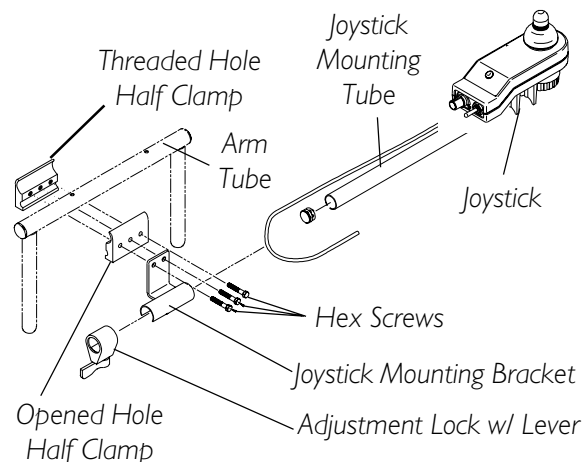

FIGURE 2 - REPOSITIONING MKIV JOYSTICK - STANDARD/ADJUSTABLE SEAT MODELS

This Section Includes the Following:

Recliner Operation

Replacing Back or Headrest Upholstery

Adjusting Back or Headrest Upholstery

RECLINER OPERATION (FIGURE 1)

WARNING

ALWAYS make sure that the wheelchair is stable **BEFORE** using the recliner option.

NEVER operate the wheelchair while in any recline position over 105° **RELATIVE TO THE SEAT FRAME**. If the limit switch does not stop the wheelchair from operating in a recline position greater than 105° **RELATIVE TO THE SEAT FRAME**, do not operate the wheelchair. Have the limit switch adjusted by an authorized Invacare dealer or qualified technician.

Both gas cylinders **MUST** be operational and adjusted properly **BEFORE** using the recliner. **DO NOT** operate the recliner option if only one (1) of the gas cylinders is operational or adjusted properly.

When using the recliner option, the motor/gearbox or motor **MUST** use the **MOST** rearward mounting holes on the suspension arm assembly.

TO HEALTHCARE PROFESSIONALS/ASSISTANTS:

Make sure the occupant of the wheelchair is properly positioned.

When returning the occupant of the wheelchair to the full upright position, more body strength will be required for approximately the last twenty (20) degrees of incline (reverse recline). Make sure to use proper body mechanics (use your legs) or seek assistance if necessary to avoid injury.

1. Make sure the wheelchair is on a level surface.
2. Inform the occupant of the wheelchair that the wheelchair is about to be reclined.
3. Stand behind the wheelchair and grasp both back canes firmly.
4. Pull up on the handles of the recliner cable assemblies to release the gas cylinders.
5. **SLOWLY**, push down on the back canes while squeezing the handles of the recliner cable assemblies in a continuous motion.

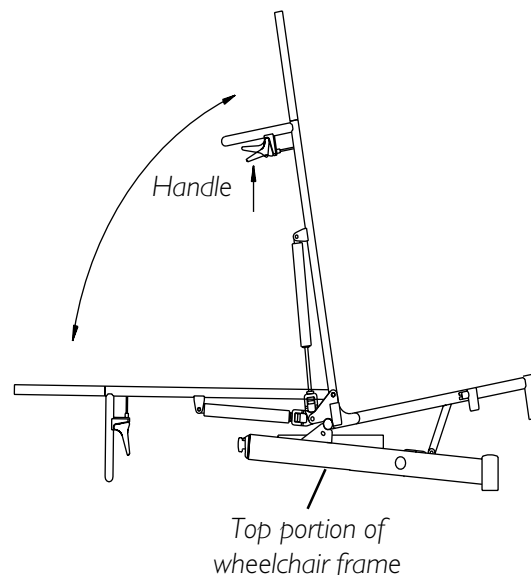

FIGURE 1 - RECLINER OPERATION

6. When the back reaches the desired angle, SLOWLY let go of the handles of the recliner cable assemblies.
7. To return the back to the full upright position, reverse the above steps keeping in mind proper body mechanics.

REPLACING BACK OR HEADREST UPHOLSTERY (FIGURE 2)

REPLACING BACK UPHOLSTERY

1. Remove the ten (10) or twelve (12) mounting screws (depending on back height) that secure the back upholstery to the back canes.
2. Remove existing back upholstery from back canes.
3. Install the new back upholstery onto the back canes.
4. Install the ten (10) or twelve (12) mounting screws (depending on back height) that secure the back upholstery to the recliner back canes.
5. Adjust the back upholstery to the desired tautness. Refer to ADJUSTING BACK OR HEADREST UPHOLSTERY in this section of the manual.

NOTE: Changing the back upholstery height must be performed by an authorized dealer or qualified technician.

REPLACING HEADREST UPHOLSTERY

1. Remove the six (6) mounting screws that secure the headrest upholstery to the headrest extensions.
2. Remove the existing headrest upholstery from the headrest extensions.
3. Install the new headrest upholstery onto the headrest extensions.
4. Install the six (6) mounting screws that secure the headrest upholstery to the headrest extensions.
5. Adjust the headrest upholstery to the desired tautness. Refer to ADJUSTING BACK OR HEADREST UPHOLSTERY in this section of the manual.

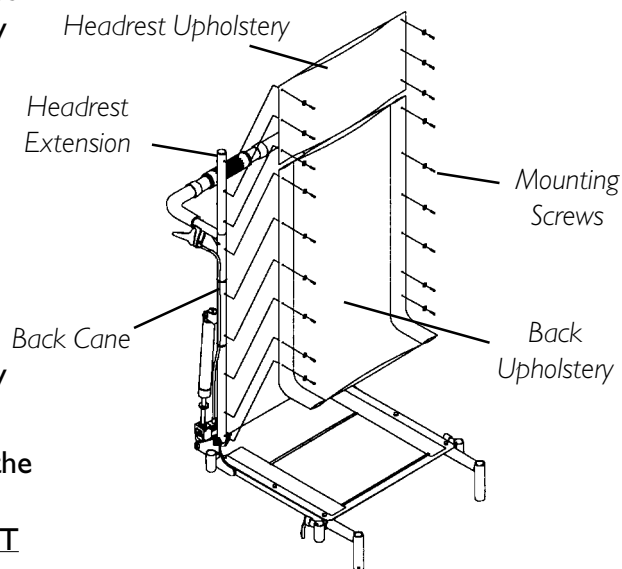

FIGURE 2 - REPLACING BACK OR HEADREST UPHOLSTERY

ADJUSTING BACK OR HEADREST UPHOLSTERY (FIGURE 3)

- I. Rotate the spreader bar either:
 - A. **COUNTERCLOCKWISE** (away from back upholstery) to **LOOSEN** back/headrest upholstery
 - OR**
 - B. **CLOCKWISE** (towards back upholstery) to **TIGHTEN** back/headrest upholstery

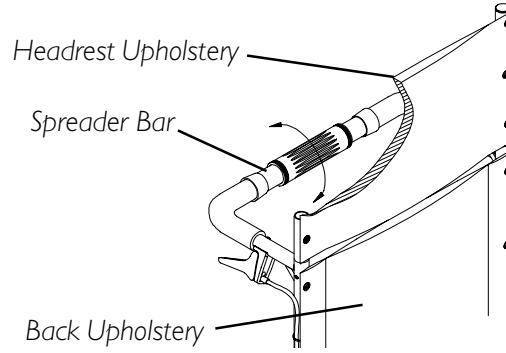

FIGURE 3 - ADJUSTING BACK OR HEADREST UPHOLSTERY

LIMITED WARRANTY

PLEASE NOTE: THE WARRANTY BELOW HAS BEEN DRAFTED TO COMPLY WITH FEDERAL LAW APPLICABLE TO PRODUCTS MANUFACTURED AFTER JULY 4, 1975.

This warranty is extended only to the original purchaser/user of our products.

This warranty gives you specific legal rights and you may also have other legal rights which vary from state to state.

Invacare warrants seat frame to be free from defects in materials and workmanship for a period of three (3) years from date of purchase; that electrical components are warranted for a period of one (1) year; gearbox/motors for a period of 18 months; and gearless/brushless motors for five (5) years from the date of purchase; and the base frame for the life of the product; all remaining components (including gas cylinders and motor lock pads) for one (1) year from the date of purchase except upholstered materials, padded materials and tires/wheels. If within such warranty period any such product shall be proven to be defective, such product shall be repaired or replaced, at Invacare's option. This warranty does not include any labor or shipping charges incurred in replacement part installation or repair of any such product. Invacare's sole obligation and your exclusive remedy under this warranty shall be limited to such repair and/or replacement.

This warranty pertains to Arrow Series, Ranger X Series and Torque SP Series Only!

For warranty service, please contact the dealer from whom you purchased your Invacare product. In the event you do not receive satisfactory warranty service, please write directly to Invacare at the address at the bottom of the back cover. Provide dealer's name, address, date of purchase, indicate nature of the defect and, if the product is serialized, indicate the serial number. Do not return products to our factory without our prior consent.

LIMITATIONS AND EXCLUSIONS: THE FOREGOING WARRANTY SHALL NOT APPLY TO SERIAL NUMBERED PRODUCTS IF THE SERIAL NUMBER HAS BEEN REMOVED OR DEFACED, PRODUCTS SUBJECTED TO NEGLIGENCE, ACCIDENT, IMPROPER OPERATION, MAINTENANCE OR STORAGE, COMMERCIAL OR INSTITUTIONAL USE, PRODUCTS MODIFIED WITHOUT INVACARE'S EXPRESS WRITTEN CONSENT INCLUDING, BUT NOT LIMITED TO, MODIFICATION THROUGH THE USE OF UNAUTHORIZED PARTS OR ATTACHMENTS; PRODUCTS DAMAGED BY REASON OF REPAIRS MADE TO ANY COMPONENT WITHOUT THE SPECIFIC CONSENT OF INVACARE, OR TO A PRODUCT DAMAGED BY CIRCUMSTANCES BEYOND INVACARE'S CONTROL, AND SUCH EVALUATION WILL BE SOLELY DETERMINED BY INVACARE. THE WARRANTY SHALL NOT APPLY TO PROBLEMS ARISING FROM NORMAL WEAR OR FAILURE TO ADHERE TO THESE INSTRUCTIONS.

THE FOREGOING EXPRESS WARRANTY IS EXCLUSIVE AND IN LIEU OF ANY OTHER WARRANTIES WHATSOEVER, WHETHER EXPRESS OR IMPLIED, INCLUDING THE IMPLIED WARRANTIES OF MERCHANTABILITY AND FITNESS FOR A PARTICULAR PURPOSE, AND THE SOLE REMEDY FOR VIOLATIONS OF ANY WARRANTY WHATSOEVER, SHALL BE LIMITED TO REPAIR OR REPLACEMENT OF THE DEFECTIVE PRODUCT PURSUANT TO THE TERMS CONTAINED HEREIN. THE APPLICATION OF ANY IMPLIED WARRANTY WHATSOEVER SHALL NOT EXTEND BEYOND THE DURATION OF THE EXPRESS WARRANTY PROVIDED HEREIN. INVACARE SHALL NOT BE LIABLE FOR ANY CONSEQUENTIAL OR INCIDENTAL DAMAGES WHATSOEVER.

THIS WARRANTY SHALL BE EXTENDED TO COMPLY WITH STATE/PROVINCIAL LAWS AND REQUIREMENTS.

Invacare Corporation

www.invacare.com



USA

One Invacare Way
Elyria, Ohio USA
44036-2125
800-333-6900

Canada

570 Matheson Blvd E.
Unit 8 Mississauga,
Ontario
L4Z 4G4, Canada
800-668-5324

Invacare, Storm Series, and Arrow
are registered trademarks
Ranger X, Troque SP and Yes,
You can. is a trademark of

Invacare Corporation.

© 2003 Invacare Corporation
Part No. I104782 Rev. C - 2/03